



Suggested Specification

Model PGVSBF is a non-refrigerated fountain and delivers ambient water. Shall include the VersaFiller Bottle Filler with mechanical activation; lower unit shall have a single vandal resistant push button to activate the flow of water. Bottle Filler alcove and cabinet finish shall be stainless steel. Key VersaFiller components contain Freshield®, which utilizes a silver-based antimicrobial compound to protect the surfaces from discoloration, odors and degradation caused by the growth of micro-organisms and mildew. Basin shall be designed to eliminate splashing and standing water. Water saver bubbler to reduce waste water by 50% and shall have flexible guard and operate between 20 and 100 PSI. Cabinet finish shall be brushed stainless steel. Cabinet shall have galvanized steel screens to prevent objects from being inserted into ventilation panel or underside of unit. Shall comply with ANSI 117.1 and ADA. Shall be listed by Underwriters Laboratories to US and Canadian standards. Shall comply with NSF/ANSI 61 and NSF/ANSI 372.

Features:	• Built-in 100 micron strainer stops particles before they enter the waterway
	• Waterways are Lead-Free in materials & construction
	• Vandal resistant water saver bubbler infused with silver-based antimicrobial additive
	• Vandal resistant fasteners
	• Galvanized steel louver and bottom screens
	• Stainless steel top and heavy duty galvanized steel frame
	• Includes integral self-scouring waste drain
	• Access to stream height adjustment on lower VersaCooler fountain
	• Ample space within the bottle filler cabinet to add filtration, including all OASIS filters
	• Logos permanently formed into the alcove and stainless steel wrapper

Filtration System:	Option to add filtration
Power:	No electricity required
Activation By:	Independent Manual Activation on Bottle Filler and Fountain
Mounting Type:	Wall Mounted
Chilling Option:	Non-Refrigerated
Full Load Amps	0 amps
Rated Watts	0
Approx. Net Weight	32 lbs
Installation Location:	Indoor

VANDAL RESISTANT SINGLE DRINKING FOUNTAIN,
NON-REFRIGERATED & MECHANICAL BOTTLE FILLER
MODEL PGVSBF



Ships in one box.

Installation

- Prior to roughing in, consult with local, state and federal codes for proper mounting height
- Shipped with complete instructions and wall mounting bracket
- Removable side and front panels provide easy access for installation

Finishes

- Standard cabinet finish: Stainless steel

Limited 1-Year Warranty

(Continental limits of the United States and Canada)
One year on bottle fillers and electrical components. Detailed warranty certificate enclosed with each water cooler; sample available upon request.

Export Warranty

One year on components parts. Detailed warranty certificate enclosed with each drinking fountain; sample copy available upon request.

Certifications/Compliance

- Certified to UL 399 and CAN/CSA C22.2 No.120 (electric water coolers only)
- Product Certified to NSF/ANSI Standard 61-G & 372 and conforms with the lead content requirements for "Lead Free" plumbing as defined by California, Vermont, Maryland, and Louisiana state laws and the U.S. Safe Drinking Water Act
- These water coolers comply with the requirements of ADA (Americans with Disabilities Act) when properly installed

MODEL: _____ QTY: _____
 PROJECT: _____
 CONTACT: _____
 NOTES: _____
 APPROVAL: _____ DATE: _____



WARNING:
Cancer and Reproductive Harm
www.P65Warnings.ca.gov



Specifications subject to change without notice



VANDAL RESISTANT SINGLE DRINKING FOUNTAIN,
NON-REFRIGERATED & MECHANICAL BOTTLE FILLER
MODEL PGVSBF

Accessories



OASIS VersaFilter III Replacement Cartridge

OASIS Item #041145-001

- Certified to NSF/ANSI 42, 53 and 401 for lead, Particulate Class I, chlorine, taste, odor and microplastics reduction to 4,750 gallons.



OASIS Total PFAS Replacement Cartridge

OASIS Item #041668-001

- Certified to NSF/ANSI 42, 53 and 401 for chlorine, taste, odor, particulate class 1, lead, cysts, Total PFAS, and microplastics reduction to 1,100 gallons.



OASIS Pharmaceutical Replacement Cartridge

OASIS Item #041670-001

- Certified to NSF/ANSI 42, 53 and 401 for chlorine, taste, odor, particulate class 1, lead, cysts, Atenolol, Bisphenol A, Carbamazepine, DEET (diethyltoluamide), Estrone, Ibuprofen, Meprobamate, Metolachlor, Naproxen, Nonyl phenol, Phenytoin and Trimethoprim, and microplastics reduction to 725 gallons.



One piece chrome plated brass bubbler

OASIS Item #036700-001



Cane apron

Stainless Steel Finish, OASIS Item #035174-003

- ADA Compliant Apron is needed when water cooler is not installed in an alcove or with right and left wing walls. OASIS Apron is to provide the mandatory 27" to floor ADA requirement.



[View all filters and accessories](#)



VANDAL RESISTANT SINGLE DRINKING FOUNTAIN,
NON-REFRIGERATED & MECHANICAL BOTTLE FILLER
MODEL PGVSBF

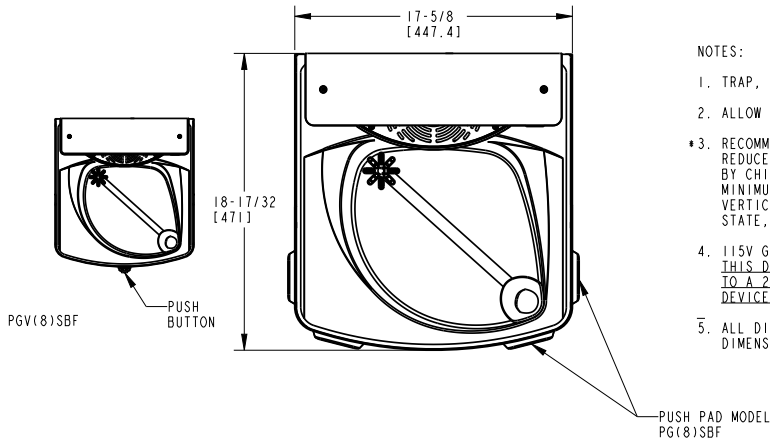

NOTES:

1. TRAP, STOP VALVE AND ELECTRICAL OUTLET NOT FURNISHED.
2. ALLOW 4 INCHES [102MM] MIN. PER SIDE FOR VENTILATION.
3. RECOMMENDED ADULT BARRIER FREE HEIGHT INSTALLATION SHOWN. REDUCE HEIGHT BY 3 INCHES FOR INSTALLATIONS USED PRIMARILY BY CHILDREN AGES 12 AND YOUNGER. UNIT SHALL ALSO HAVE A MINIMUM CLEAR FLOOR SPACE 20[1760] BY 48[1220]. ADJUST VERTICAL DIMENSIONS AS REQUIRED TO COMPLY WITH FEDERAL, STATE, AND LOCAL CODES.
4. 115V GROUNDED NORTH AMERICAN DUPLEX RECEPTACLE REQUIRED. THIS DRINKING WATER COOLER IS INTENDED TO BE CONNECTED TO A 20A MINIMUM GROUND FAULT CIRCUIT INTERRUPTING (GFCI) DEVICE TO MEET UL REQUIREMENTS.
5. ALL DIMENSIONS ARE IN INCHES. DIMENSIONS IN BRACKETS [] ARE IN MILLIMETERS.

