



# VERSACOOLER™ SINGLE DRINKING FOUNTAIN, NON-REFRIGERATED & MECHANICAL BOTTLE FILLER MODEL PGSBF

## Suggested Specification

Model PGSBF is a non-refrigerated fountain and delivers ambient water. Model PGSBF shall include PG8AC and the VersaFiller Bottle Filler with independent push button manual activation; lower unit shall have four push pads to activate the manual flow of water for the cooler. Bottle Filler alcove and cabinet finish shall be stainless steel. Key VersaFiller components contain Freshield®, which utilizes a silver-based antimicrobial compound to protect the surfaces from discoloration, odors and degradation caused by the growth of micro-organisms and mildew. Basin shall be designed to eliminate splashing and standing water. Water saver bubbler to reduce waste water by 50% and shall have flexible guard and operate between 20 and 100 PSI. Cabinet finish shall be brushed stainless steel. Shall comply with ANSI 117.1 and ADA. Shall be listed by Underwriters Laboratories to US and Canadian standards. Shall comply with NSF/ANSI 61 and NSF/ANSI 372.



- Features:**
- Built-in 100 micron strainer stops particles before they enter the waterway
  - Waterways are Lead-Free in materials & construction
  - Stainless steel top and heavy duty galvanized steel frame
  - Ample space within the bottle filler cabinet to add filtration, including all OASIS filters
  - Access filter through the top of the bottle filler for clean and easy replacement of filters with Tilt 'N Tether
  - Flexible one-piece water saver bubbler infused with silver-based antimicrobial additive
  - Includes integral self-scouring waste drain
  - External access to stream height adjustment on lower VersaCooler fountain
  - Logos permanently formed into the alcove and stainless steel wrapper

<b>Filtration:</b>	Option to add filtration
<b>Power:</b>	No electricity required
<b>Activation By:</b>	Independent Manual Activation on Bottle Filler and Fountain
<b>Mounting Type:</b>	Wall Mounted
<b>Chilling Option:</b>	Non-Refrigerated
<b>Full Load Amps</b>	0 amps
<b>Rated Watts</b>	0
<b>Approx. Net Weight</b>	30 lbs
<b>Installation Location:</b>	Indoor

**Ships in one box.**

### Installation

- Prior to roughing in, consult with local, state and federal codes for proper mounting height
- Shipped with complete instructions and wall mounting bracket

### Finishes

- Standard: Greystone powder coat on galvanized steel
- Optional finishes: Sandstone powder coated paint; Stainless steel (at additional cost)

### Limited 1-Year Warranty

(Continental limits of the United States and Canada)  
One year on bottle fillers and electrical components. Detailed warranty certificate enclosed with each water cooler; sample available upon request.

### Export Warranty

One year on components parts. Detailed warranty certificate enclosed with each drinking fountain; sample copy available upon request.

### Certifications/Compliance

- Certified to UL 399 and CAN/CSA C22.2 No.120 (electric water coolers only)
- Product Certified to NSF/ANSI Standard 61-G & 372 and conforms with the lead content requirements for "Lead Free" plumbing as defined by California, Vermont, Maryland, and Louisiana state laws and the U.S. Safe Drinking Water Act
- These water coolers comply with the requirements of ADA (Americans with Disabilities Act) when properly installed

MODEL: \_\_\_\_\_ QTY: \_\_\_\_\_  
 PROJECT: \_\_\_\_\_  
 CONTACT: \_\_\_\_\_  
 NOTES: \_\_\_\_\_  
 APPROVAL: \_\_\_\_\_ DATE: \_\_\_\_\_



**WARNING:**  
Cancer and Reproductive Harm  
[www.P65Warnings.ca.gov](http://www.P65Warnings.ca.gov)



Specifications subject to change without notice



# VERSACOOLER™ SINGLE DRINKING FOUNTAIN, NON-REFRIGERATED & MECHANICAL BOTTLE FILLER MODEL PGSBF

## Accessories



### OASIS VersaFilter III Universal Retrofit Kit

OASIS Item #041253-001

- Add filtration to your unit - retrofit into all OASIS fountains and bottle fillers. Certified to NSF/ANSI 42, 53 and 401 for lead, Particulate Class I, chlorine, taste, odor and microplastics reduction to 4,750 gallons.



### OASIS Total PFAS Universal Retrofit Kit

OASIS Item #041253-005

- Add filtration to your unit - retrofit into all OASIS fountains and bottle fillers. Certified to NSF/ANSI 42, 53 and 401 for chlorine, taste, odor, particulate class 1, lead, cysts, Total PFAS, and microplastics reduction to 1,100 gallons.



### OASIS Pharmaceutical Universal Retrofit Kit

OASIS Item #041253-006

- Add filtration to your unit - retrofit into all OASIS fountains and bottle fillers. Certified to NSF/ANSI 42, 53 and 401 for chlorine, taste, odor, particulate class 1, lead, cysts, Atenolol, Bisphenol A, Carbamazepine, DEET (diethyltoluamide), Estrone, Ibuprofen, Meprobamate, Metolachlor, Naproxen, Nonyl phenol, Phenytoin and Trimethoprim, and microplastics reduction to 725 gallons.



### One piece chrome plated brass bubbler

OASIS Item #036700-001



### Cane apron

Greystone Finish, OASIS Item # 035174-001

Sandstone Finish, OASIS Item # 035174-002

Stainless Steel Finish, OASIS Item #035174-003

- ADA Compliant Apron is needed when water cooler is not installed in an alcove or with right and left wing walls. OASIS Apron is to provide the mandatory 27" to floor ADA requirement.



[View all filters and accessories](#)



# VERSACOOLER™ SINGLE DRINKING FOUNTAIN, NON-REFRIGERATED & MECHANICAL BOTTLE FILLER MODEL PGSBF

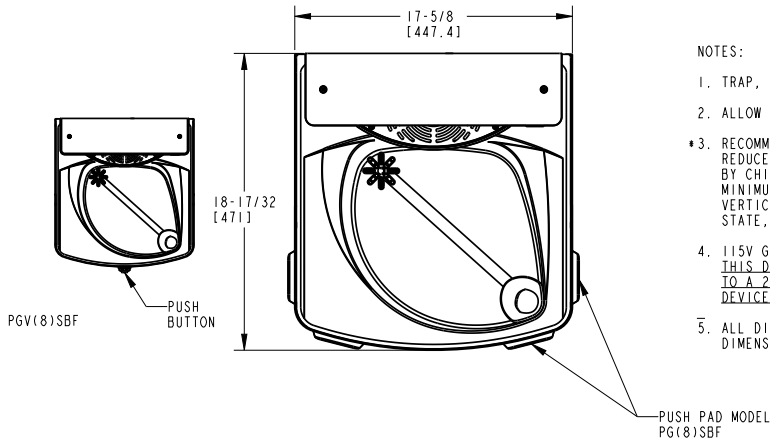

**NOTES:**

1. TRAP, STOP VALVE AND ELECTRICAL OUTLET NOT FURNISHED.
2. ALLOW 4 INCHES [102MM] MIN. PER SIDE FOR VENTILATION.
3. RECOMMENDED ADULT BARRIER FREE HEIGHT INSTALLATION SHOWN. REDUCE HEIGHT BY 3 INCHES FOR INSTALLATIONS USED PRIMARILY BY CHILDREN AGES 12 AND YOUNGER. UNIT SHALL ALSO HAVE A MINIMUM CLEAR FLOOR SPACE 20[1760] BY 48[1220]. ADJUST VERTICAL DIMENSIONS AS REQUIRED TO COMPLY WITH FEDERAL, STATE, AND LOCAL CODES.
4. 115V GROUNDED NORTH AMERICAN DUPLEX RECEPTACLE REQUIRED. THIS DRINKING WATER COOLER IS INTENDED TO BE CONNECTED TO A 20A MINIMUM GROUND FAULT CIRCUIT INTERRUPTING (GFCI) DEVICE TO MEET UL REQUIREMENTS.
5. ALL DIMENSIONS ARE IN INCHES. DIMENSIONS IN BRACKETS [ ] ARE IN MILLIMETERS.

