



Water Coolers

QUASAR Contactless Bottle Filler

UV-C LED WATER TREATMENT

Model PWEBQ and PWF2EBQ (retro fit) and PG*EBQ Family of Drinking Fountains/Bottle Filler combo

Installation Instructions



The Contactless Bottle Filler mounts directly above Versacooler® I and II products.

If installed onto a refrigerated cooler, chilled water can be dispensed through the Bottle Filler. Otherwise, room temperature water will be dispensed.

The Bottle Filler is shipped partially assembled.

On the combo units, the cooler is plumbed and ready to attach to the Bottle Filler.

When completed, the finished assembly will look like this:

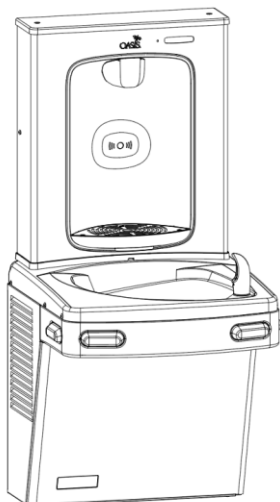

OR



What's Included:

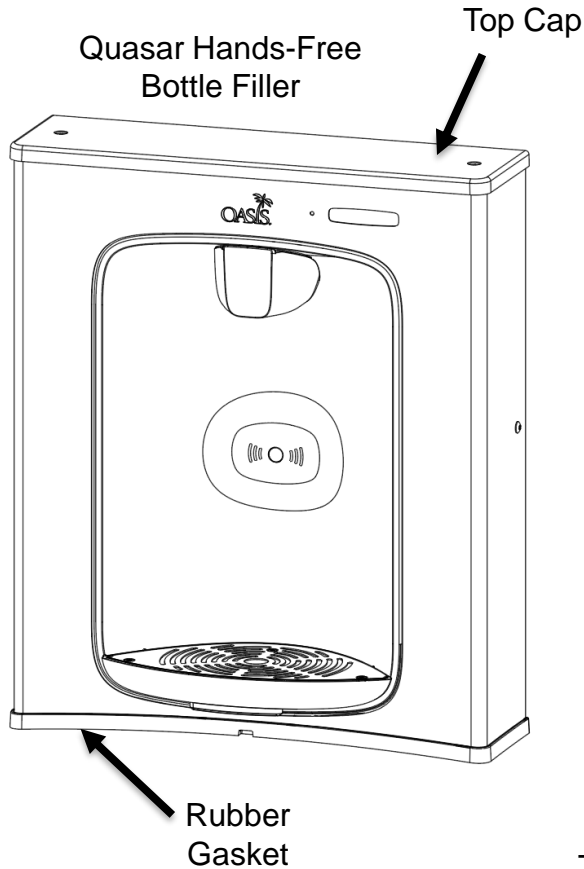

38" of 1/4 OD plastic tubing with 38" of sponge tubing insulation

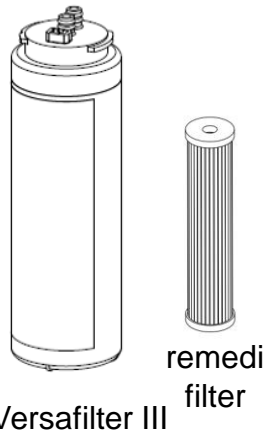

The Versafilter III and remedifilter are only included in Model PWF2EBQ



Snap bushings 7/8" and 1 1/2"

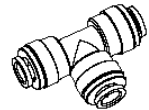

Quick connect tee fitting



Quick connect elbow fitting

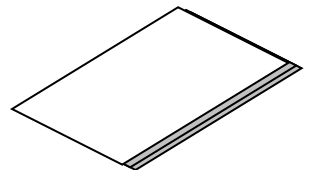

Installation instructions

Tools required:

- 3/8" pilot drill and either a step drill bit up to 7/8" diameter that will drill through SS top or 7/8" diameter punch die (retrofit version only)
- Electric drill; wrench for punch die
- Small tubing cutter for copper tube
- 1/4" nut driver
- # 2 Phillips screwdriver
- #15 torx bit driver

Section 2: IMPORTANT REQUIREMENT

CAUTION: ENSURE BOTTLE FILLER IS PROPERLY GROUNDED. IT IS REQUIRED TO ATTACH THE LONG GREEN GROUND WIRE TO THE FRAME ASSEMBLY. REFER TO THE STEPS DESCRIBED ON STEPS 6-8 ON PAGE 19.

CAUTION: DO NOT ACTIVATE BOTTLE FILLER ELECTRIC EYE SENSOR WITHOUT RUNNING WATER THROUGH THE UV-C MODULE. OPERATING THE UV-C MODULE DRY MAY DAMAGE THE UV-C LED'S.

Section 3A: QUASAR® UV-C LED OPERATION

1. QUASAR is a form of dispense point water treatment that utilizes UV-C LED's to inactivate pathogens.
2. Operation:
 - a. The QUASAR activation is automatic. The UV-C LED's turn ON when water is dispensed and OFF when the dispense stops.
 - b. During non-use periods the QUASAR automatically cycles ON for ten seconds every ten minutes. This keeps the dispense point more sanitary between use.
 - c. When the QUASAR is ON, the LED light on the front of the alcove near the top will turn BLUE.
 - d. If QUASAR is not working properly, then the LED light on the front of the alcove near the top will be ORANGE. The light will remain ORANGE and the system will not allow water to be dispensed until the problem is resolved.
 - e. **IMPORTANT:** Never operate the QUASAR without water connected to the system. Lack of water can cause the QUASAR to overheat. If it is necessary to activate QUASAR to purge the system of air, then the QUASAR will automatically shut off if it overheats. The QUASAR will resume operation once water begins to flow through it.

Section 3B: LED Indicator Key

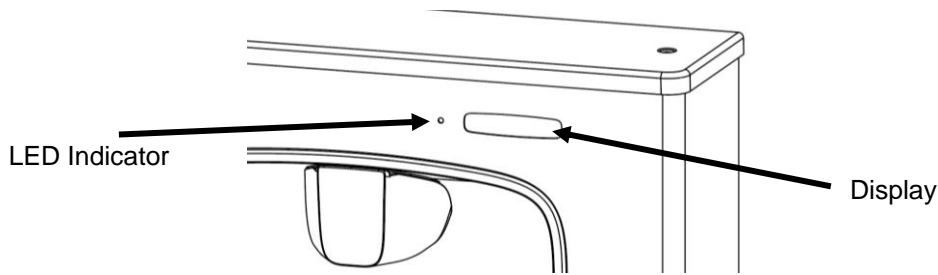

LED Color	Display	Condition	Action
Orange	"UVC OFF- TURN ON WATER SUPPLY"	While dispensing, UVC temperature is too high.	Ensure water supply is ON. If initial start-up: Activate the bottle filler to dispense water. LED will turn BLUE when water flows.
Green	"BOTTLES SAVED"	Standby mode – filter life <80% used.	No action needed.
Yellow	"BOTTLES SAVED"	Standby mode – filter life >80% used but <100%.	Order new filter.
Red	"BOTTLES SAVED"	Standby mode – filter life =100% used.	Replace the filter.
Blue	"UVC DISINFECTION IN PROCESS"	Dispensing – bottle sensed by IR sensor and UVC operating properly.	No action needed.
Orange	"UVC REQUIRES SERVICE" (Remains ON even in standby.)	Water cannot be dispensed.	Check electrical connections to UVC and reset power first. Replace UVC if necessary.

Section 4: Rough In Drawing

Oasis PWEBQ, PWF2EBQ: Versacooler® II Models PGAC, PG8AC with Hands-Free Bottle Filler

NOTES:

1. TRAP, STOP VALVE AND ELECTRICAL OUTLET NOT FURNISHED.
2. ALLOW 4 INCHES [102 MM] MIN. PER SIDE FOR VENTILATION.
3. RECOMMENDED ADULT BARRIER FREE HEIGHT INSTALLATION SHOWN. REDUCE HEIGHT BY 3 INCHES FOR INSTALLATIONS USED PRIMARILY BY CHILDREN AGES 12 AND YOUNGER. UNIT SHALL ALSO HAVE A MINIMUM CLEAR FLOOR SPACE 30[760] BY 48[1220]. ADJUST VERTICAL DIMENSIONS AS REQ'D TO COMPLY WITH FEDERAL, STATE, AND LOCAL CODES.
4. 115v GROUNDED NORTH AMERICAN DUPLEX RECEPTACLE REQUIRED. THIS DRINKING WATER COOLER IS INTENDED TO BE CONNECTED TO A 20A MINIMUM GROUND FAULT CIRCUIT INTERRUPTING (GFCI) DEVICE TO MEET UL REQUIREMENTS.
5. ALL DIMENSIONS ARE IN INCHES. DIMENSIONS IN BRACKETS [] ARE IN MILLIMETERS.

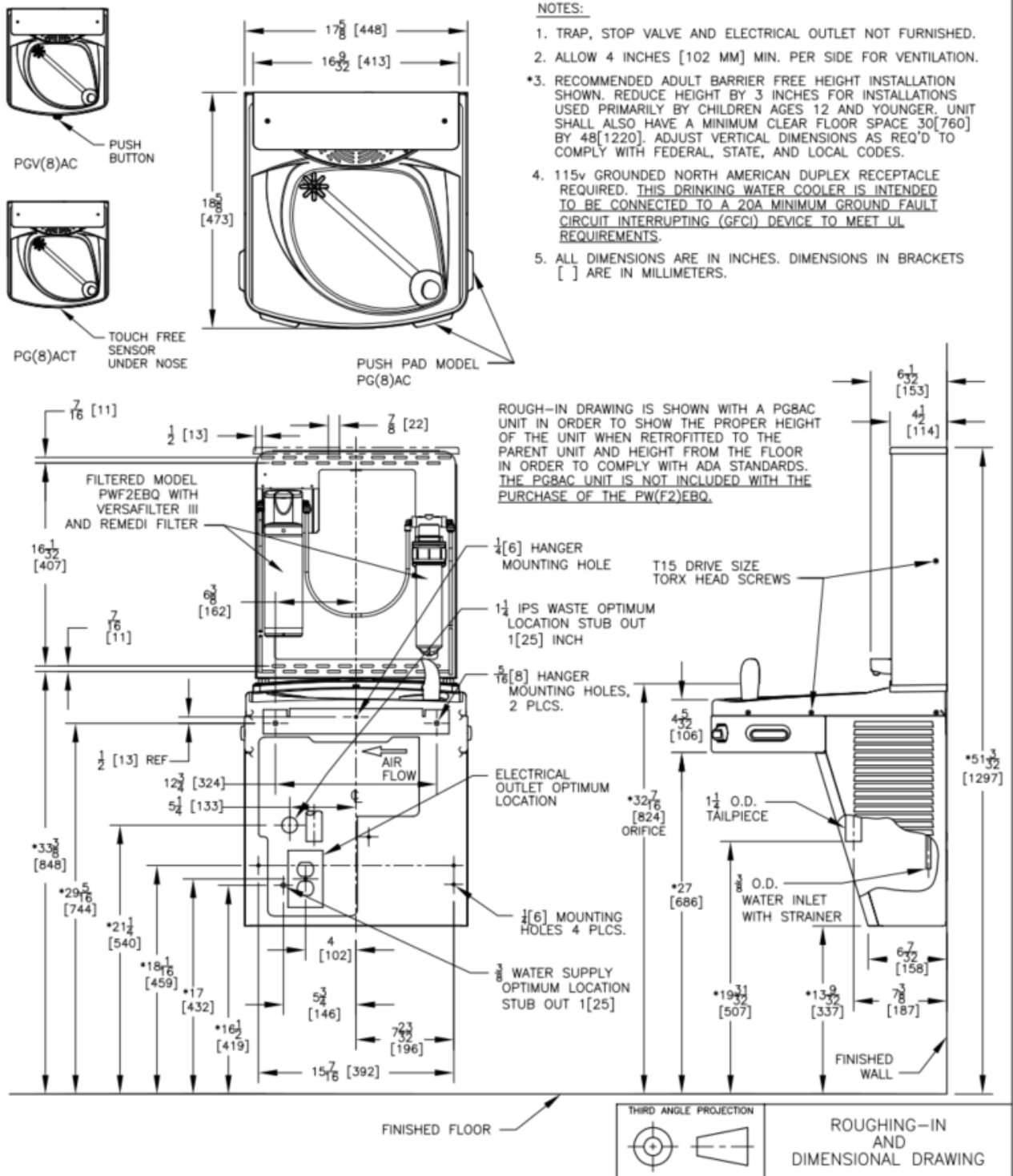

Section 4: Rough In Drawing

Oasis PWEBQ, PWF2EBQ: Versacooler® II Split Level Models with Hands-Free Bottle Filler

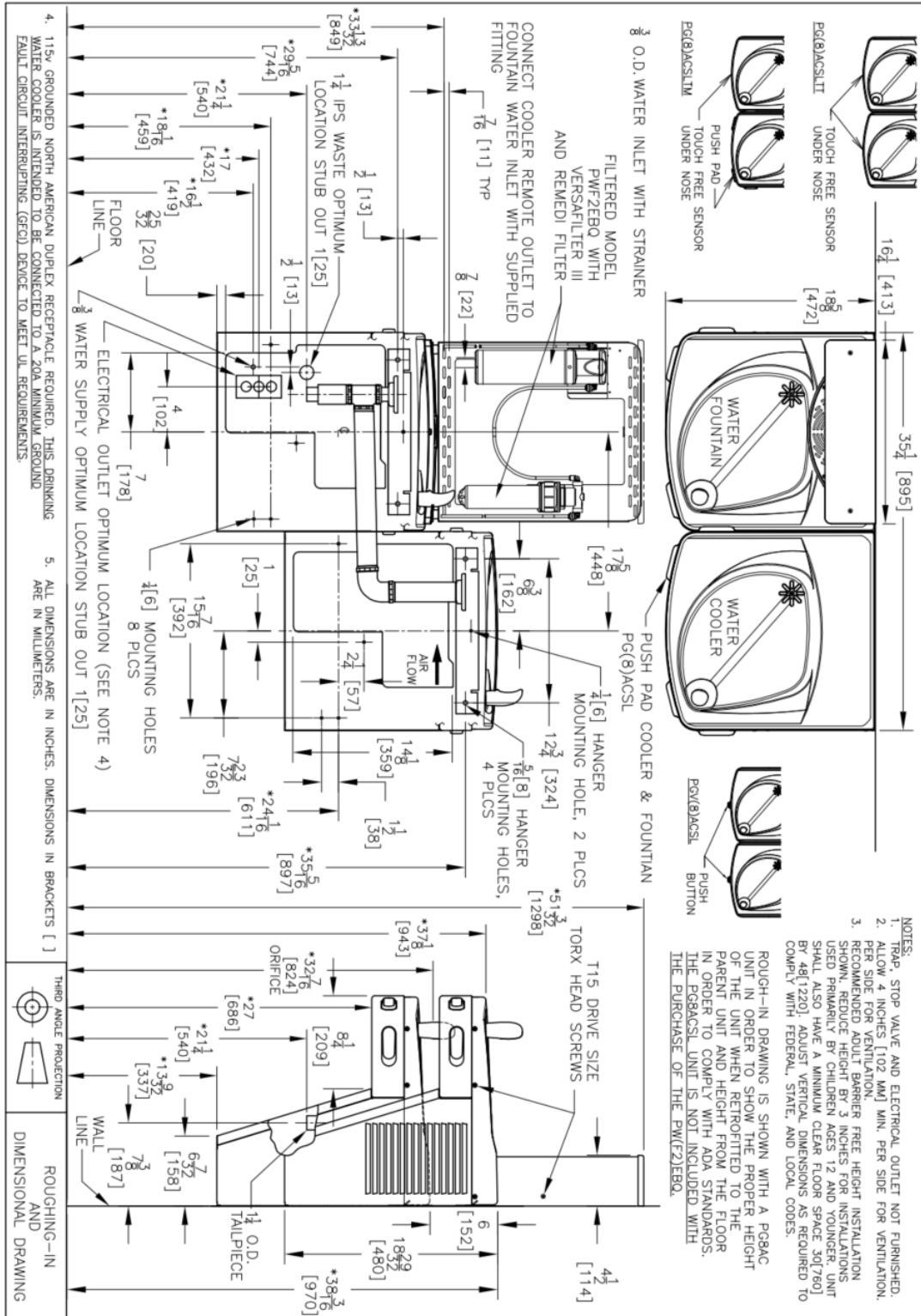

* On split level models, the Bottle Filler must be mounted on the low unit in order to meet ADA guidelines.

Section 5A: Installation

Note: Proceed to Section 3B Step 5 “Final steps for both product families” if the cooler is purchased “Quasar Bottle Filler or VersaFiller ready”.

A: Drilling hole in the top for water line connection.

1. Disconnect power by UNPLUGGING unit. It might be necessary to remove the front panel to get access to the power.
2. Turn OFF water supply to the unit. It might be necessary to remove the front panel to access the water stop valve.
3. Place hole template onto cooler top so it is aligned with the left side of unit and wall. SEE NEXT PAGE FOR TEMPLATE
4. Mark hole location
5. Remove top from unit.

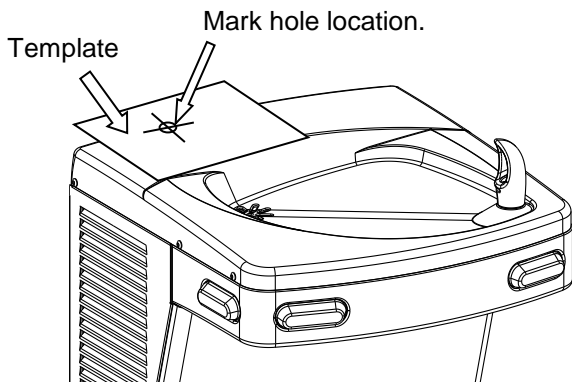

Remove top from cooler by removing six, #15 torx head screws on sides of top.

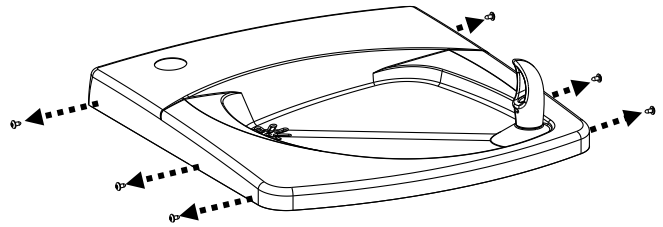

6. Using a step drill bit or 7/8" punch die, make a 7/8" hole through top. You may want to drill a pilot hole to get these started.
7. Install snap bushing into hole to protect tubing from being cut.

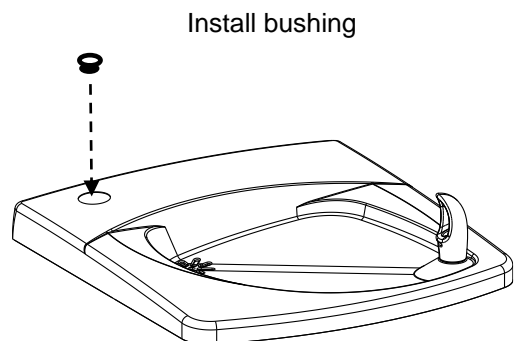
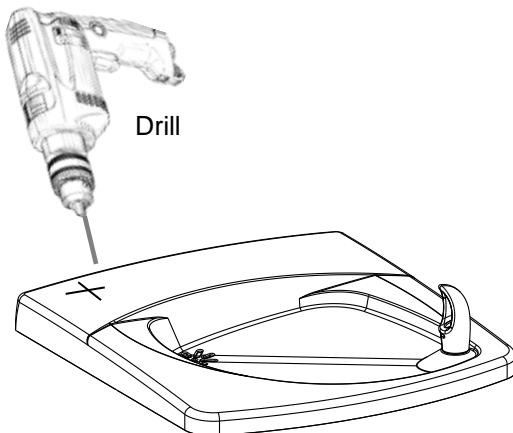

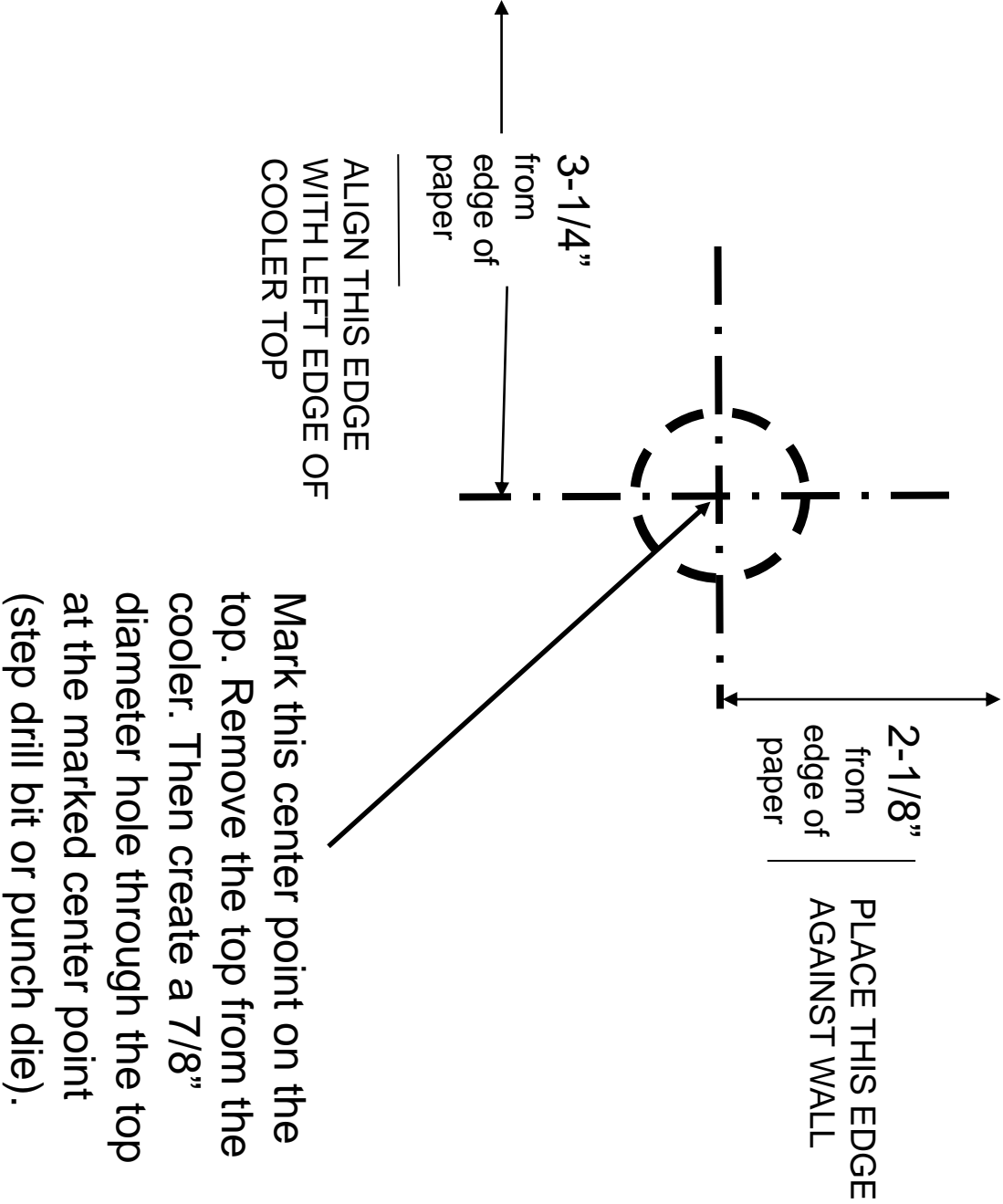

USE THIS TEMPLATE TO MARK THE HOLE LOCATION ON COOLER TOP

VersaCooler to Quasar Bottle Filler Plumbing Diagram

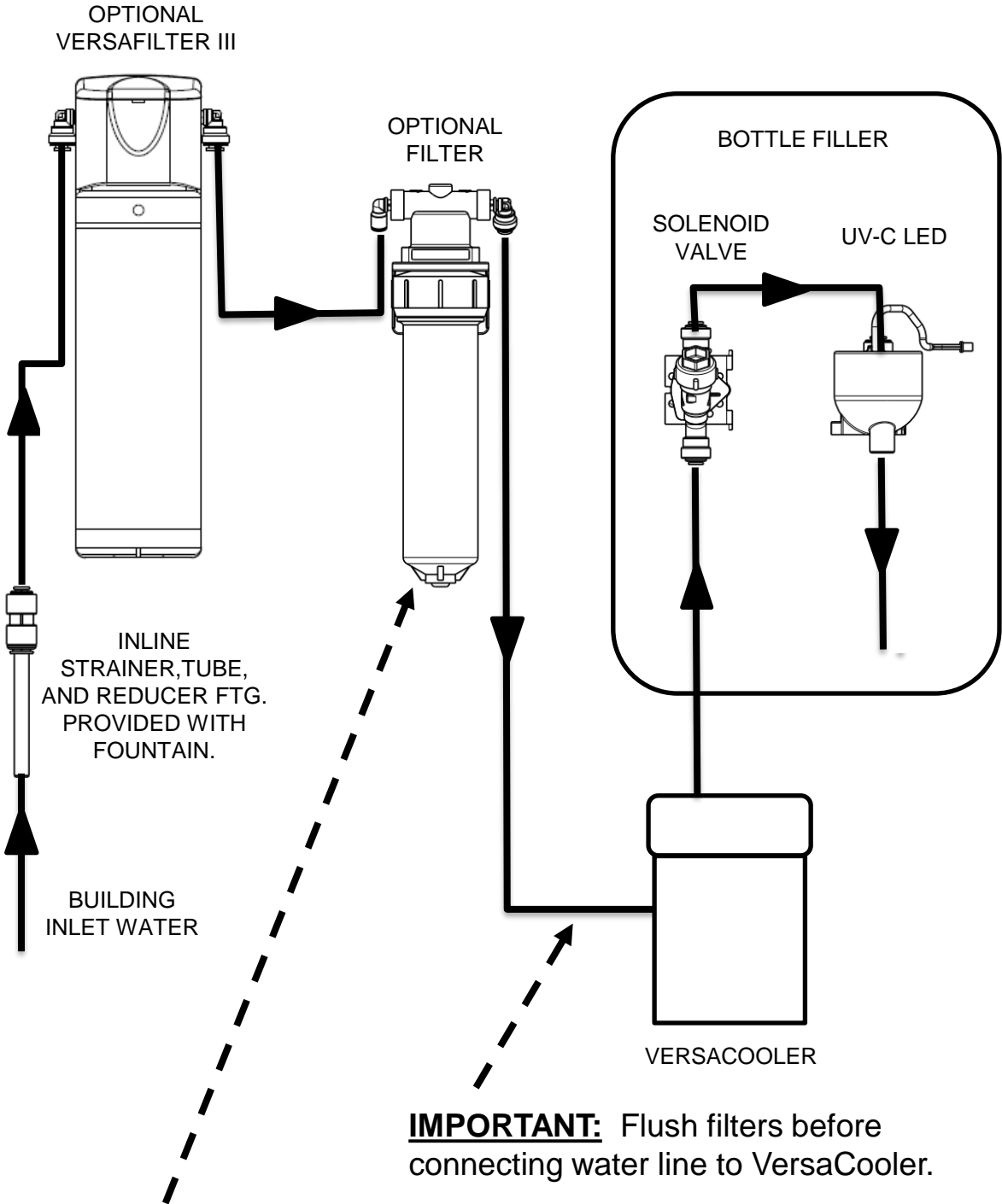

IMPORTANT: When replacing filter cartridge, turn off water supply. Depressurize water lines prior removal of filter housing from the quarter turn filter head assembly.

Section 5B: Installation

Two VersaCoolers to Quasar Bottle Filler Plumbing Diagram

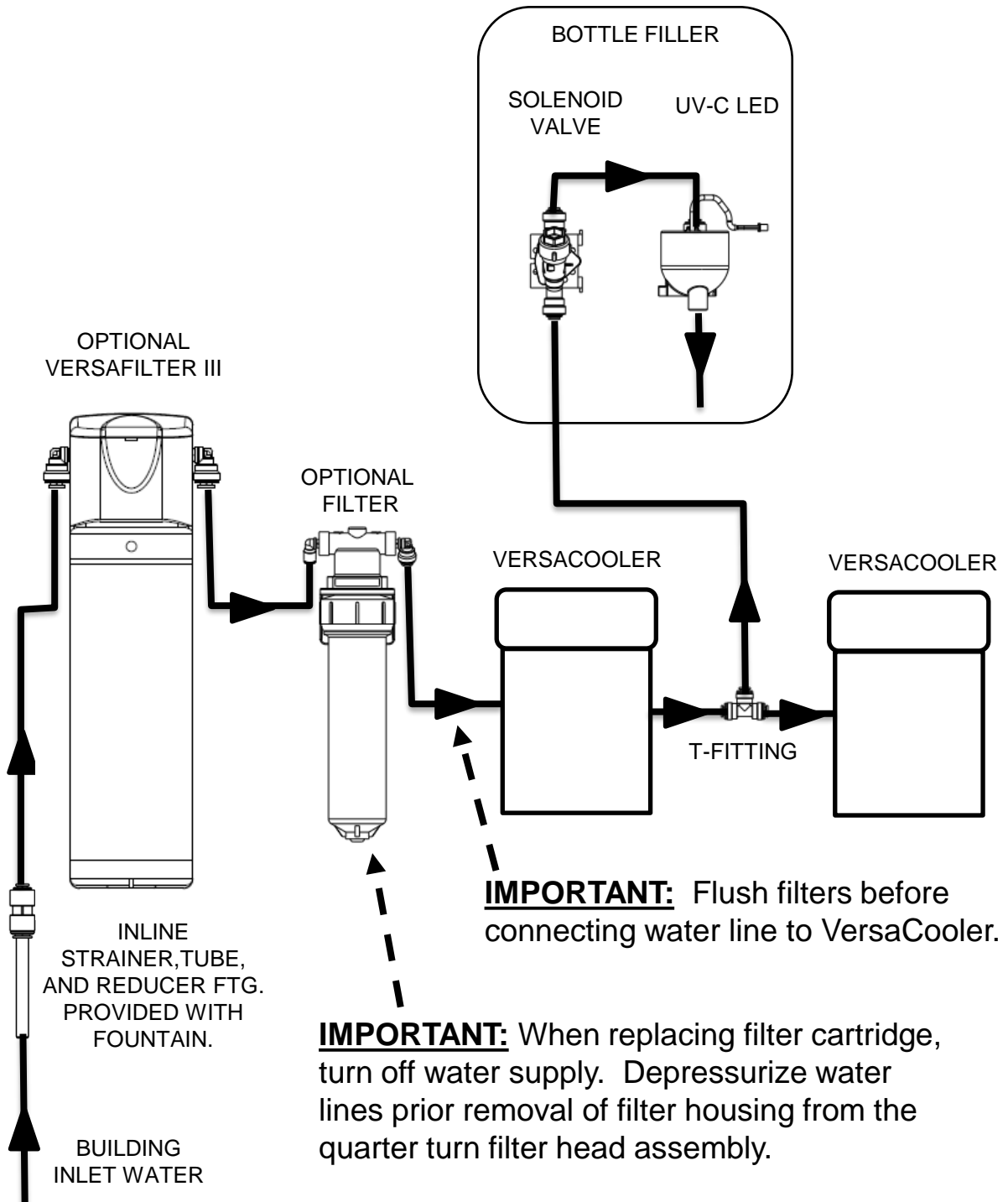

IMPORTANT: Flush filters before connecting water line to VersaCooler.

IMPORTANT: When replacing filter cartridge, turn off water supply. Depressurize water lines prior removal of filter housing from the quarter turn filter head assembly.

B: Connecting the water line

Note: If you are retrofitting the Bottle Filler to an existing cooler, follow the instructions starting on page 11.

For the single “Bottle Filler ready” cooler, the tube to connect to the Bottle Filler is found inside the access panel (the compressor compartment) or found inside the Bottle Filler. This tube supplies cold water from the cooling tank to the Bottle Filler.

1/4" OD tube to connect to Versafiller



For split level “Bottle Filler ready” coolers, the tube to plumb in the Bottle Filler is packaged in the dummy unit or found inside the Bottle Filler.

Remove tube from bag.



First, remove plug from fitting on tank drain

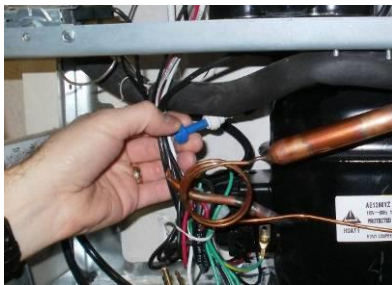

Next, insert end of tube into fitting.



The tee and tube to the Bottle Filler are packaged with the PWEBQ unit. One branch of the tee will supply the valve on the dummy unit, the other branch of the tee will connect to the Bottle Filler.

If a filter is being installed, cut a piece of tubing about 3" long to insert optional flow switch right after filter and before tee. This allows Bottle Filler counter to accurately calculate amount of water passing through filter.

Tube to connect valve
on dummy unit



Tube to connect
Bottle Filler

Tube to connect chilled
water to dummy unit
and Bottle Filler



Go to Step 5 "Final steps for both product families:"

To retrofit the Versafiller to an existing unit, follow the instructions below:

If the cooling tank is non-pressurized, then go to the “Pressurizing the cooling tank” addendum section. Otherwise, proceed to step 1 below. Non-pressurized units are single units made since December of 2009. Refer to the schematic below to identify the system that you have.

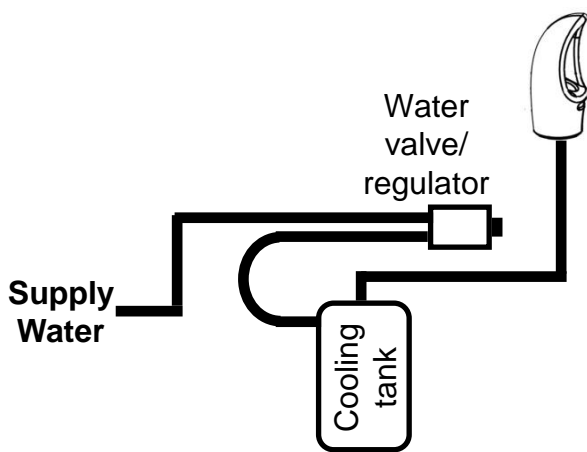

NON-PRESSURIZED COOLING TANK

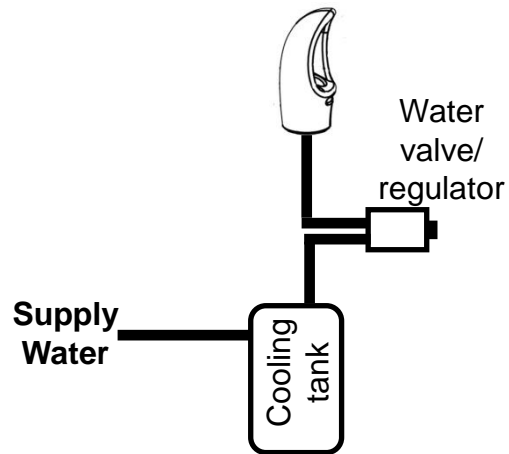

PRESSURIZED COOLING TANK

1. With the cooler top removed, find the tube going from the cooling tank outlet to the valve. The TEE fitting (supplied) will need to connect between the cooling tank and valve.

Outlet Tube (insulated plastic)



P8AC family

Outlet Tube (insulated copper)

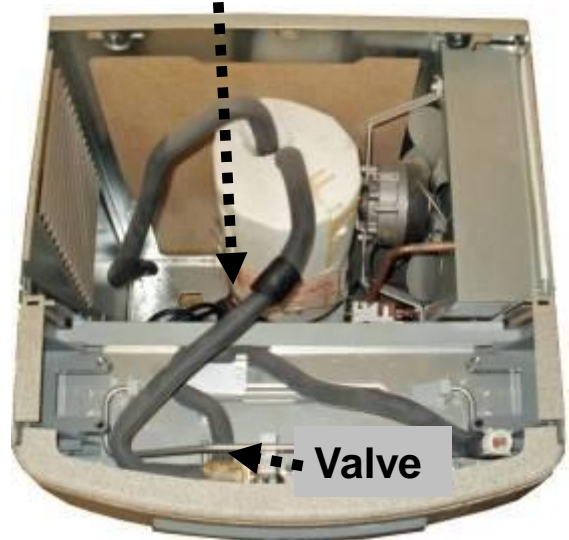

P8AM family

Section 5B: Installation: For the P8AC Version: Versacooler II

2. Disconnect tubing from the elbow on the valve.



3. Using the 38" piece of tubing provided, cut 6" and install it on the end of the TEE. Install the remaining tubing onto the branch of the TEE. Connect the other end of the TEE to the tank outlet tubing (tube that was disconnected from the elbow).



32" tubing

6" tubing

TEE

4. Route the TEE and tubing under the waste drain and connect the 6" length to the water valve elbow.



Water
valve
elbow

Go to Step 5 "Final steps for both product families:"

Section 5B: Installation: For the P8AM Version: Versacooler I

2. Remove tar tape from the insulation on the outlet tube.



3. Pull back insulation and cut the copper tube with a tubing cutter. Cut where there is at least 1 inch of *straight* tubing on each side of the cut.



4. Install TEE fitting by connecting the copper tubing to each end. Then install the 32" piece of plastic tubing to the TEE branch.



Section 5B: Installation: **Final steps for both product families:**

5. Feed tube up through the top and attach the top to the cooler.

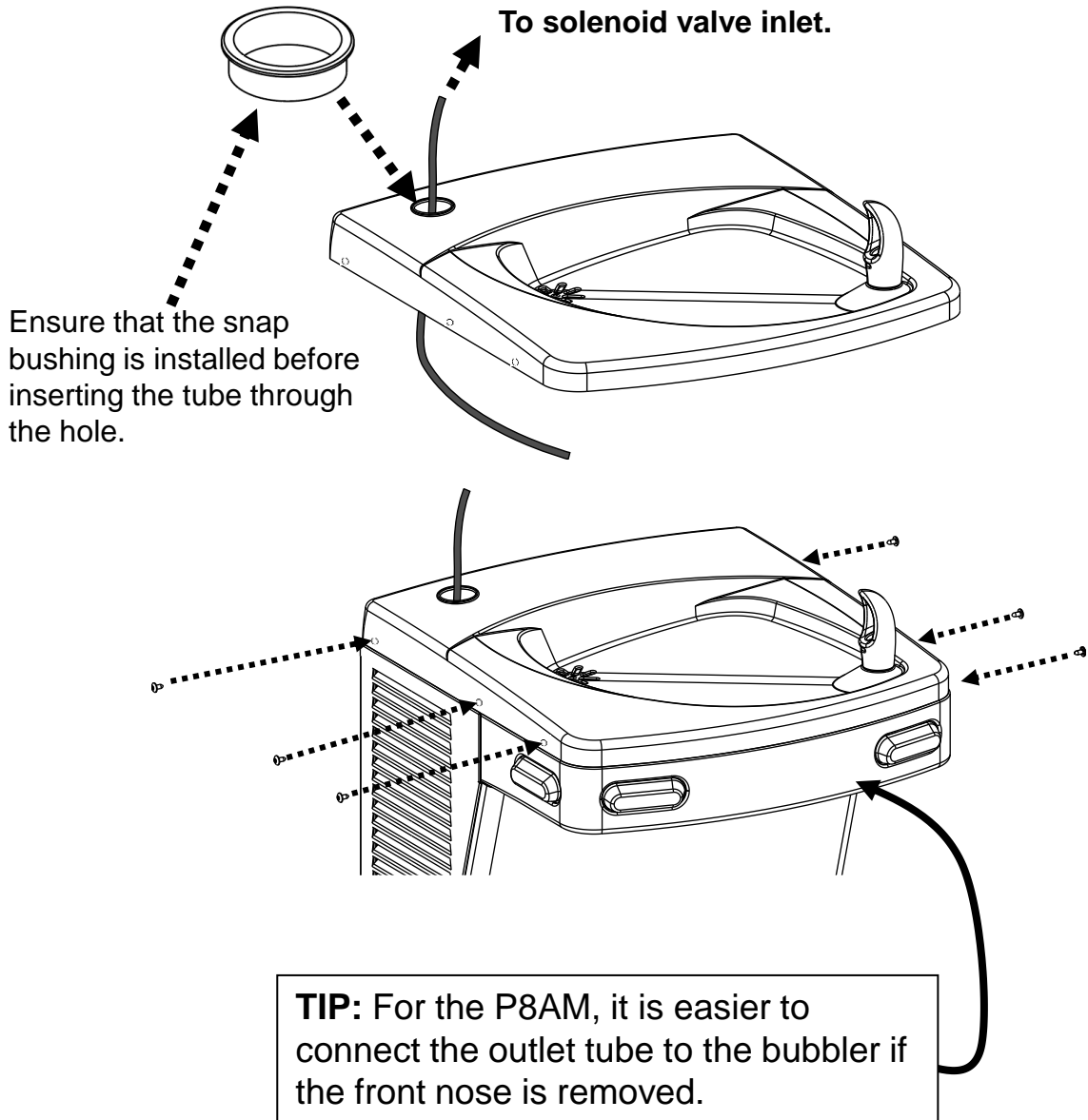

C: Mounting the frame to the wall

1. Place rubber gasket on top of the cooler so it is centered left/right and against the wall.
2. Set the wall frame onto the gasket. Center it left/right and push it against the wall and mark hole locations for wall fasteners. The gasket will set the frame at the proper height.

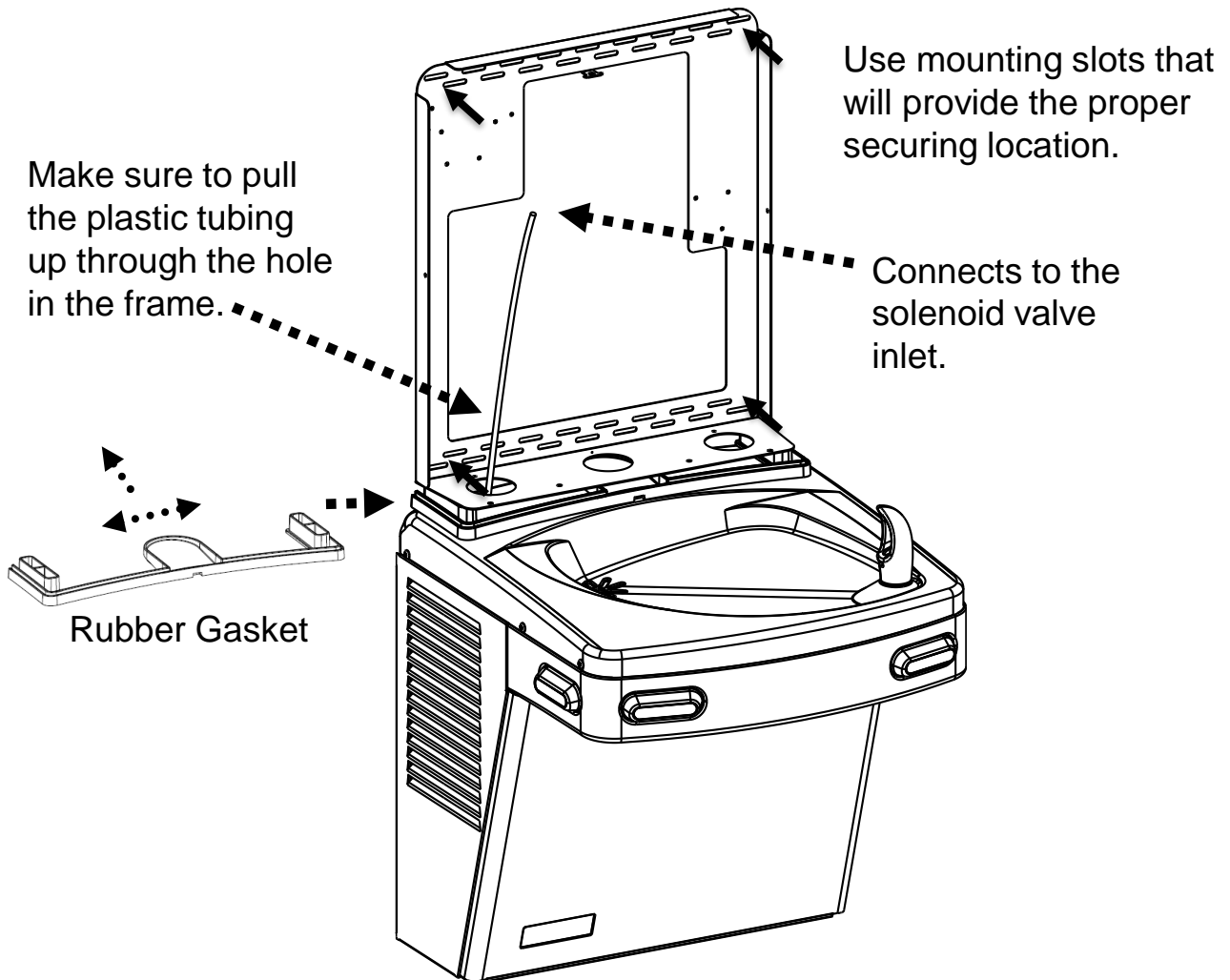

3. Secure frame to the wall with fasteners (not provided). Pull plastic tubing up through the hole in the frame.

C: Installing and Flushing Filter Cartridges (PWF2EBQ only)

1. Insert VersaFilter III filter cartridge, rotate $\frac{1}{4}$ turn until locked.
2. Route water supply plastic tube attached to VersaFilter III head inlet (left side) through hole in frame and top. Connect to fountain water supply.
3. Route remedi filter outlet tube attached to filter head outlet (right side) to fountain drain in top. Flush filter cartridges before connecting to fountain cooling tank inlet fitting.
4. Turn ON the water supply and flush the filters for one-minute or until the water runs clear.
5. Connect the filter outlet tube to cooling tank inlet.

VersaFilter III
Head Assembly

Route water supply
plastic tube through
hole in frame and
hole in top. Connect
to fountain water
supply.

VersaFilter III
Filter Cartridge

Route remedi filter
outlet tube to
fountain drain in
top. Flush filter
cartridges before
connecting to
fountain inlet.

Tube connects to
the solenoid valve
inlet elbow fitting
on bottle filler.

Remedi Filter
Cartridge
pre-assemble

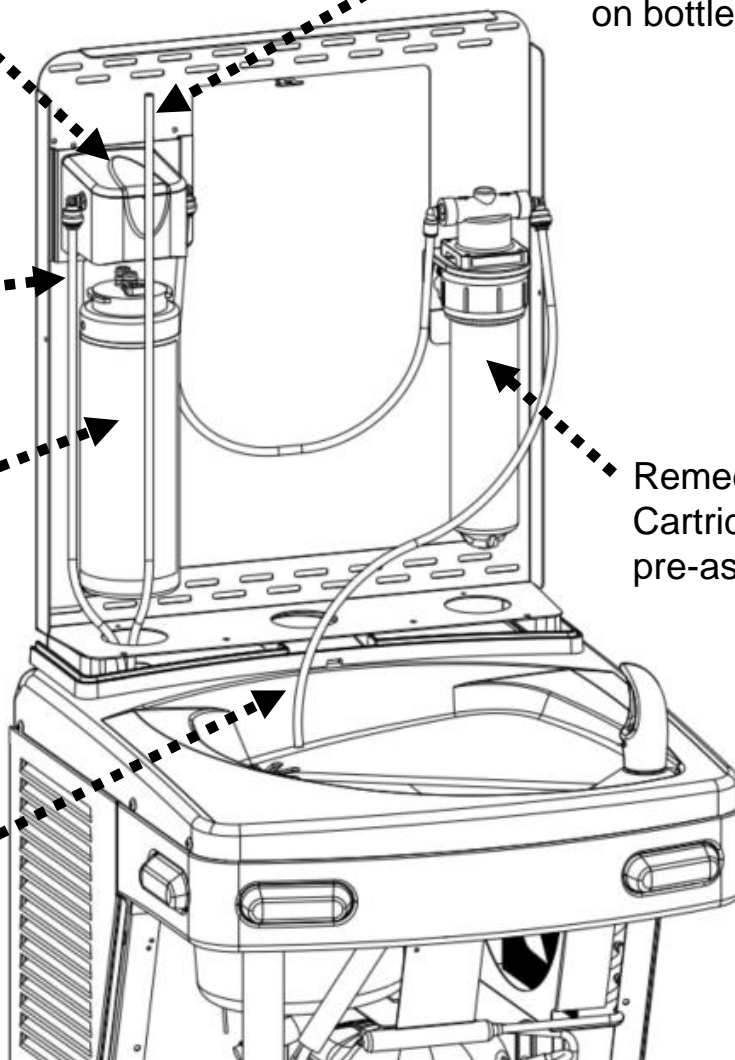

Section 5C: Installation

- Slide sponge tubing insulation over water line. Connect the tubing to the INLET of the solenoid on the back of the Hands-free Bottle Filler assembly.

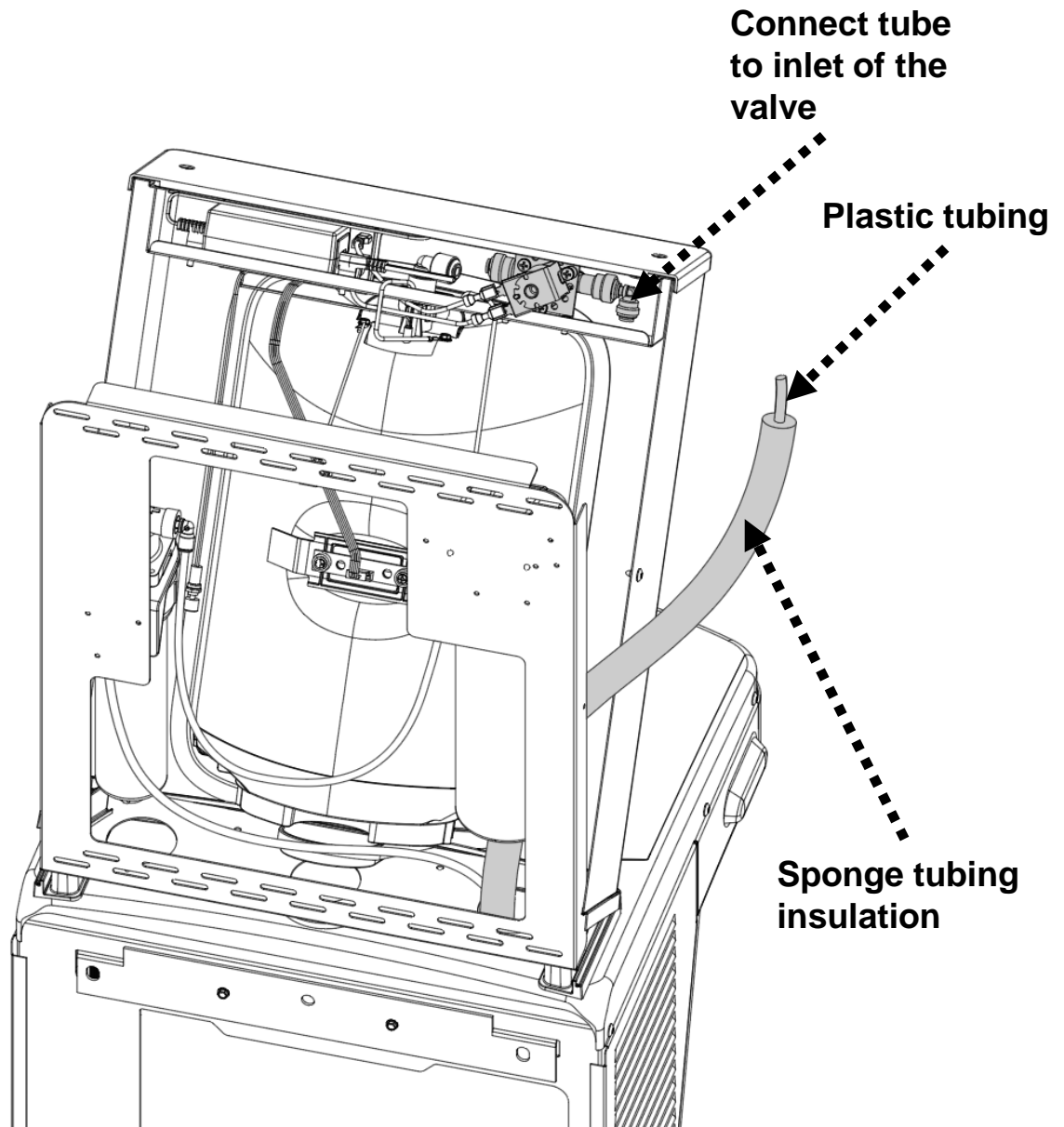

D: Attaching the Tether

5. Install bottle filler tether with the steps below.

Attach the tether line assembled to the bottle filler dispense bracket to the cleat on the mounting frame.

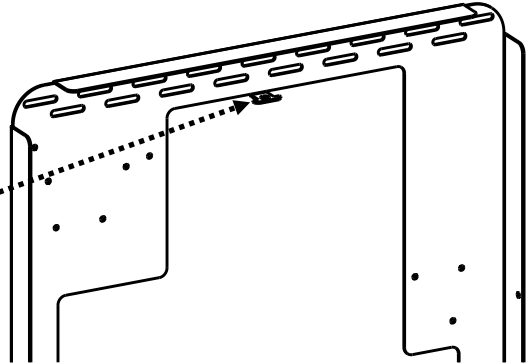

1.

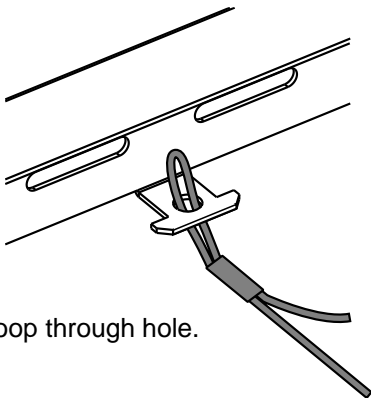

Push loop through hole.

2.

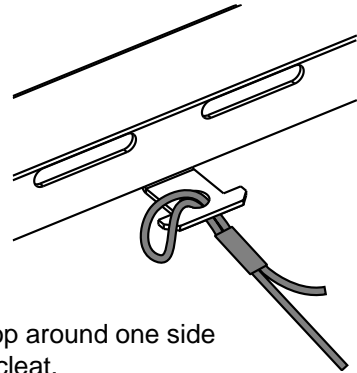

Put loop around one side of the cleat.

3.

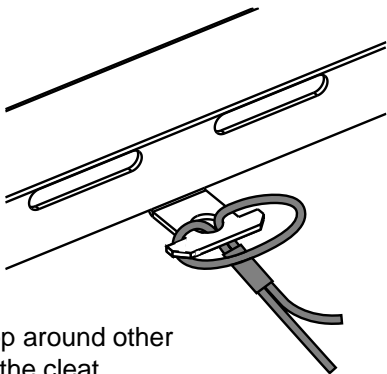

Pull loop around other side of the cleat.

4.

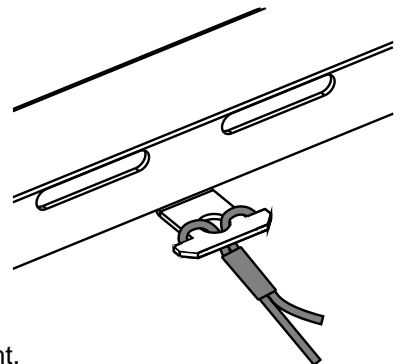

Pull tight.

The tether keeps the bottle filler secured to the frame when changing the filter, if installed. Make sure the tether is installed properly to avoid accidental damage to the unit.

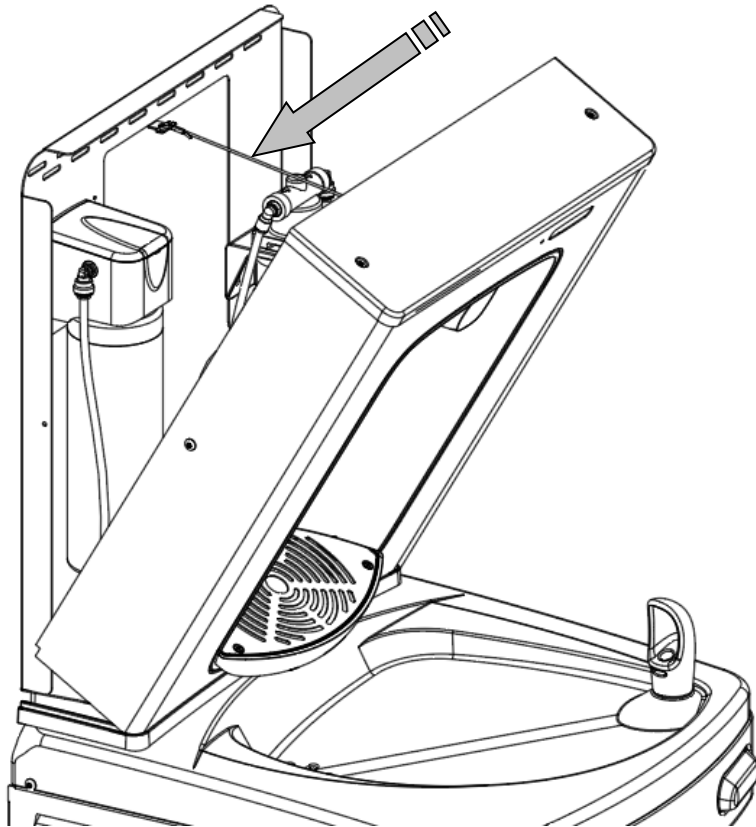

6. Before the Bottle Filler cabinet is set into place, feed the terminals on the power supply power cord and the long green ground wire through the bushing on the cooler top.
7. Connect male terminals on the bottle filler power supply to female terminals on power cord. **DO NOT** plug in the bottle filler power cord in the electrical outlet at this time. **SEE STEPS 11-13** when to plug in bottle filler power cord.
8. Attach the long green ground wire to cooler power cord ground located on cooler frame or to electrical box ground.

Section 5: Installation

9. MAKE SURE the cabinet fits into the *groove* in the rubber gasket on both sides and front of the wrapper.

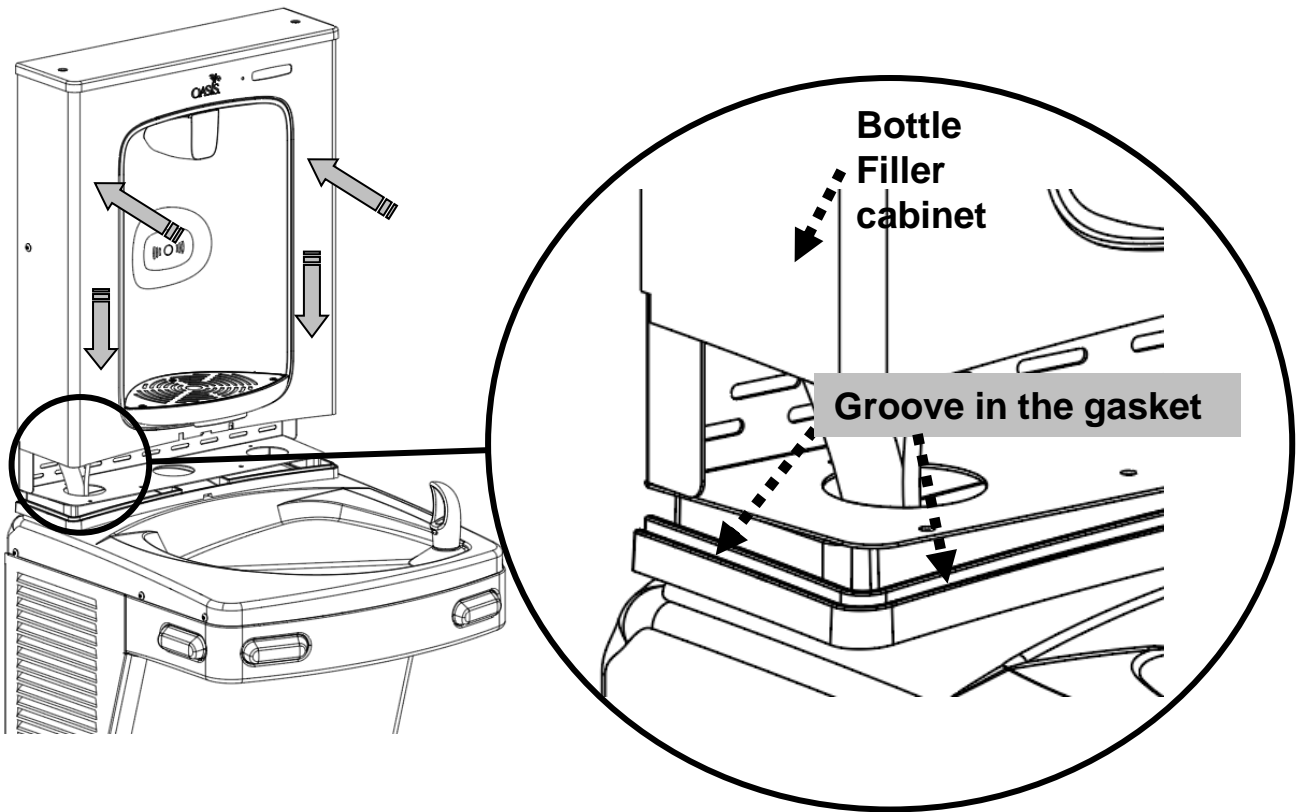

See next page to secure Bottle Filler assembly to frame with torx screws.

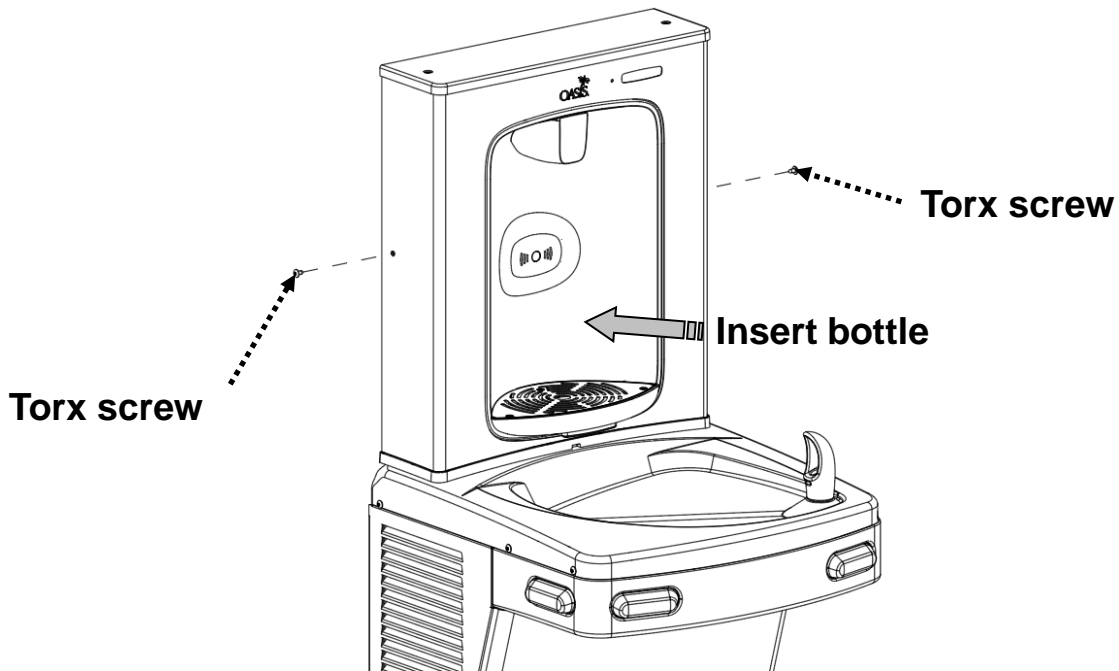

10. Attach Bottle Filler assembly to the frame using two (2) torx screws. Remove the Top Cap and two (2) torx screws used for mounting.

11. **IMPORTANT:**

REVIEW Section 3: QUASAR UV-C LED OPERATION before proceeding. Failure to follow Section 3 can damage the QUASAR.

- a. Turn ON water supply and check for leaks.
 - b. Purge air from drinking fountain bubbler(s) by activating pushbutton(s) or electrical eye sensor.
10. Plug bottle filler cord into the electrical outlet. The bottle filler will auto-calibrate and be set up specifically for that installation. Refer to the program guide on next page for further programming. Access programing Pushbutton through top of Bottle Filler.
 11. Place bottle in the bottle filler alcove to dispense water. The Water Dispenser sensor will run 20 seconds and shut-off. Do this 2 or 3 times until a steady stream of water dispenses.
 12. If everything works correctly, place the Top Cap onto the Bottle Filler and install the two (2) torx screws to fasten it in place. Otherwise, calibrate the sensor per the instructions on the next page.

Section 6: Set-up guide for bottle filler electronics

Factory default program settings are:

- a. Units - Gallons
- b. Unfiltered unit
- c. Flow Rate = 1.0 GPMD
- d. Filter Capacity = 4750 gallons [18000 liters] for VersaFilter III
- e. Bottle Count = 0.5L (1 Bottle)
- f. 20 second maximum dispense time

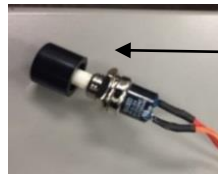

Pushbutton

To change the program settings, follow these steps:

<i><u>Display</u></i>	<i><u>Action</u></i>
00000000 BOTTLES REUSED (Home Screen)	Depress button for 3 seconds to enter into the following menu settings and make changes. Note: at anytime it will exit menu and save settings when idle for 10 seconds (no button press) and revert back to Home Screen.
LTR/GAL GAL[LTR]	Depress button 3 seconds to change from Gallons to Liters, or momentary press to advance to next menu.
UNFILT/FILT? UNFILTERED UNIT [FILTERED UNIT]	Depress button 3 seconds to change from Unfiltered to Filtered unit, or momentary press to advance to next menu.
SELECT RATE 1.0 GPMD UNIT [3.8 LPM UNIT]	To change flow rate, momentarily depress button to change whole gallon digit. Hold button 3 seconds to advance to TENTHS of gallon digit. Depress momentarily to change the digit. Hold button 3 seconds to advance to the next menu.
RESET 00000000 GALLON COUNT? [LTR COUNT?]	Depress button for 3 seconds to reset water usage count, or momentary press to advance to next menu.
FILT CAPAC OF 4750 GAL [18000 LTR]	Depress button for 3 seconds to change filter capacity to 1250 GAL [5000 LTR] for VersaFilter I. Depress button for 3 seconds to change filter capacity to 3000 GAL [11000 LTR] for VersaFilter II. Depress button for 3 seconds to change filter capacity to 4750 GAL [18000 LTR] for VersaFilter III. or momentary press to advance to next menu.
3 sec rule ? 3 sec [0.5L]	Depress button for 3 seconds to switch from 3 sec rule to 0.5L bottle, or momentary press to advance to next menu. (The 3 Sec rule increases the bottle count based on a 3 second dispense.)
RESET 00000000 BOT COUNT?	Depress button for 3 seconds to reset BOTTLES REUSED count to zero (Home Screen), or momentary press to advance to next menu.
Bot Filler Set time: 20 s	Depress button for 3 seconds to change maximum dispense time to 10, 20 or 30 seconds, or momentary press to advance to next menu.

Addendum Section: Pressurizing Cooling Tank



The water should already be turned OFF and the power disconnected.

Unit as it appears with top removed



STEP 1

Unplug un-insulated water line from water valve inlet (quick-connect elbow located left side of water valve facing the front of the cooler). Set tubing aside (careful to not contaminate water contact end).

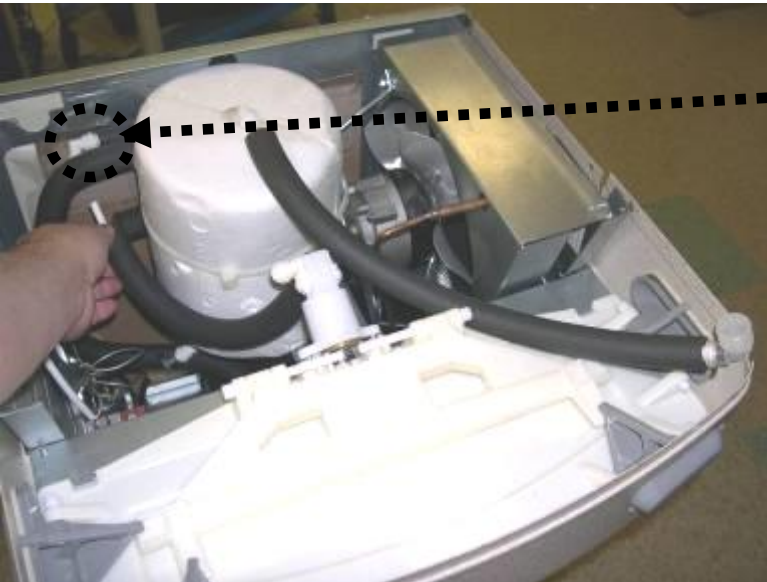

STEP 2

Unplug tubing from quick-connect elbow leading to cooling tank inlet.



STEP 3

Plug un-insulated tubing that was removed in step 1 into quick-connect elbow leading to the cooling tank from step 2.



STEP 4

Unplug tubing that is connected to the water valve outlet (quick-connect elbow located on the right side of valve facing the cooler).



STEP 5

Connect tubing from step 4 to quick-connect elbow on the left side of the valve.



Step 6

Unplug quick-connect tubing from the cooling tank outlet. Do not set it down.



Step 7

Using tubing removed in step 6, plug into quick-connect elbow on the right side of the valve. (be sure to route the tubing under existing tubing installed in step 4 as shown)



Step 8

Using tubing that is connected to the quick-connect elbow left side of valve (done in step 4), and plug the other end into the quick-connect fitting at the top of the cooling tank.



P/N 030099-681, Rev B, Date: 08/2023

© 2022 LVD Acquisition, LLC

Oasis, Aqua Pointe, Versacooler and VersaFiller are registered trademarks of LVD Acquisition, LLC dba Oasis International

Haws is a registered trademark of HAWS Corporation.

Elkay and Halsey Taylor are registered trademarks owned or licensed by Elkay Sales Inc. and/or its parent Elkay Manufacturing Company



OASIS INTERNATIONAL
222 East Campus View Blvd.
Columbus, OH 43235
614-861-1350
www.oasiscoolers.com