

**OASIS® VERSACOOLER® II MODELS  
PGVD8AC – INDOOR AND OUTDOOR RATED  
INSTRUCTIONS**

**A. INSPECTION**

Inspect carton and water cooler for evidence of rough handling and concealed damage. Damage claims should be filed with carrier.

**B. TO PUT WATER COOLER INTO SERVICE**

1. **Note:** The following states require a licensed plumber to install cooler; AR, GA, MA, MI, OK, RI, SC, SD, TX, VT and WI. CA, KS, MN, NM and OR allow for a state-registered installer or contractor as well. State and local plumbing codes may prohibit the use of saddle tapping valves for water line connection in some applications. All connections must conform to applicable plumbing codes.
2. Locate and install plumbing and electrical service, if required, in accordance with Roughing-in Drawing. Filter units have additional instructions on a label inside access panel. Read these before installing unit. This drinking water cooler is designed to be operated at a water supply line pressure of up to 100 psi (690 kPa). A pressure regulator must be installed in front of unit's water inlet if water pressure (including any possible pressure spikes) could exceed 100 psi (690 kPa).
3. **FLUSH BUILDING WATER SUPPLY LINE BEFORE INSTALLING UNIT.**
4. Install unit on wall hanger. **Wall hanger is shipped fastened to back of unit.**
5. **Install a trap in the waste line and a shut off valve in water supply line.** An in-line strainer is furnished in "Water Supply" tube. Connect "Water Supply" tube to shut off valve. This connection should not be a solder joint or flare connection to allow access to the strainer for service. To ease removal of the strainer, a sheet metal screw may be lightly threaded into the open end. **NOTE: ACTIVATION VALVE IS PLUMBED BEFORE COOLING TANK AT FACTORY TO AVOID PRESSURIZING COOLING TANK.** When unit has an internal waste trap, the trap should be wrapped with insulating tape to prevent sweating. Use of the 1-3/4 diameter knockout for a waste line is not recommended because of a potential conflict with ADA\* toe space clearance requirements. Check your local building code inspector for approval.
6. Rotate fan blade by hand to see that it is free of obstructions.
7. Check available power supply against the water cooler data plate to assure correct electrical service. This drinking water cooler is intended to be connected to a 20A minimum ground fault circuit interrupting (GFCI) device to meet UL requirements. Plug power supply cord into wall outlet. The rear most 1-3/8 diameter knockout in frame bottom is for an externally located electrical supply. Make sure knockout hole edge is smooth and free of any burrs. Use of a Heyco bushing #2184 in knocked out hole is recommended in order to prevent damage to service cord and to close up excess opening around cord. Route cord so it does not interfere with ADA\* space requirements.
8. To fill cold water tank on water cooler versions, open water supply line shut-off and push front pushbutton to allow water to flow to bubbler. Run water until stream is free of bubbles.
9. To Adjust Bubbler Stream:

All vandal resistant models are equipped with a Cartridge Regulator. To access adjustment, remove the Bezel and Button from front of cooler. Insert a screwdriver in the slot to adjust regulator. Turn adjustment clockwise to increase stream height.

**C. MAINTENANCE**

1. Inspection of condenser should be made at 3-month intervals. To remove dirt and lint from condenser, disconnect power supply cord, then use small stiff non-wire or vacuum cleaner attachment brush. Observance of this procedure will ensure adequate air circulation through condenser so operation is efficient and economical.
2. Outside of unit can be wiped clean with mild soap and water mixture. Never use harsh chemicals or abrasive cleaners, including any chlorine solutions. Rinse thoroughly with clean water, then dry surfaces.

**D. OVERLOAD PROTECTION**

The compressor motor, where used, is equipped with an automatic reset protector which will disconnect the motor from the line in case of an overload.

**E. LUBRICATION**

This unit is equipped with a hermetically sealed compressor and requires no additional lubrication. The fan motor, where used, on this unit seldom needs oiling, but if required, a few drops of SAE 10 oil should be used.

**F. TO DISCONTINUE USE OF WATER COOLER**

1. Close water shut-off valve.
2. Provide container to catch water to be drained.
3. Disconnect power supply cord then disconnect water supply line at shut off valve. Route water supply line to container and actuate pushbutton. If this drains too slowly for you, prepare 3/8" ID tube or 3/8" OD tube with quick-connect fitting and remove screw plug in tank drain. Slide tube over drain and route to container. Replace screw plug when draining is complete. Do not over-tighten. O-ring only needs to be snug to seal.
4. **ALWAYS DRAIN ALL WATER WHEN FREEZING TEMPERATURES ARE ANTICIPATED AND BEFORE SHIPPING WATER COOLER.**

\*Americans With Disabilities Act

**WARNING**

The warranty and the Underwriters' Laboratory Listing for this machine are automatically voided if this machine is altered, modified, or combined with any other machine or device. Alteration or modification of this machine may cause serious flooding and/or hazardous electrical shock or fire.

EXCEPT AS SET FORTH HEREIN, THE MANUFACTURER MAKES NO OTHER WARRANTY, GUARANTEE OR AGREEMENT EXPRESSED, IMPLIED OR STATUTORY, INCLUDING ANY IMPLIED WARRANTY OR MERCHANTABILITY OR FITNESS FOR A PARTICULAR PURPOSE.



OASIS INTERNATIONAL

222 East Campus View Blvd. • Columbus, OH 43235 U.S.A.

1-800-950-3226

www.oasiscoolers.com

# OASIS® VERSACOOLER® II MODELS PGVD8AC - INDOOR AND OUTDOOR RATED

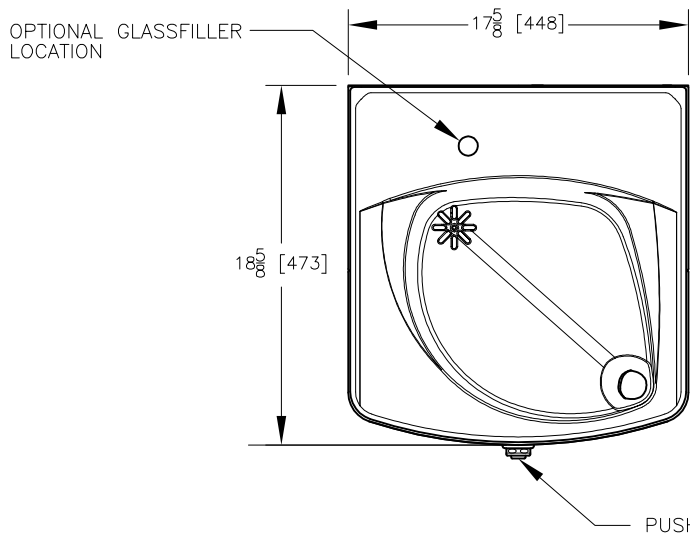

**NOTES:**

1. TRAP, STOP VALVE AND ELECTRICAL OUTLET NOT FURNISHED.
2. ALLOW 4 INCHES [102 MM] MIN. PER SIDE FOR VENTILATION.
- \* 3. RECOMMENDED ADULT BARRIER FREE HEIGHT INSTALLATION SHOWN. REDUCE HEIGHT BY 3 INCHES FOR INSTALLATIONS USED PRIMARILY BY CHILDREN AGES 12 AND YOUNGER. UNIT SHALL ALSO HAVE A MINIMUM CLEAR FLOOR SPACE 30[760] BY 48[1220]. ADJUST VERTICAL DIMENSIONS AS REQ'D TO COMPLY WITH FEDERAL, STATE, AND LOCAL CODES.
4. ALL DIMENSIONS ARE IN INCHES. DIMENSIONS IN BRACKETS [ ] ARE IN MILLIMETERS.

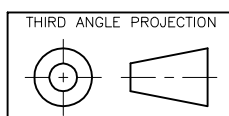
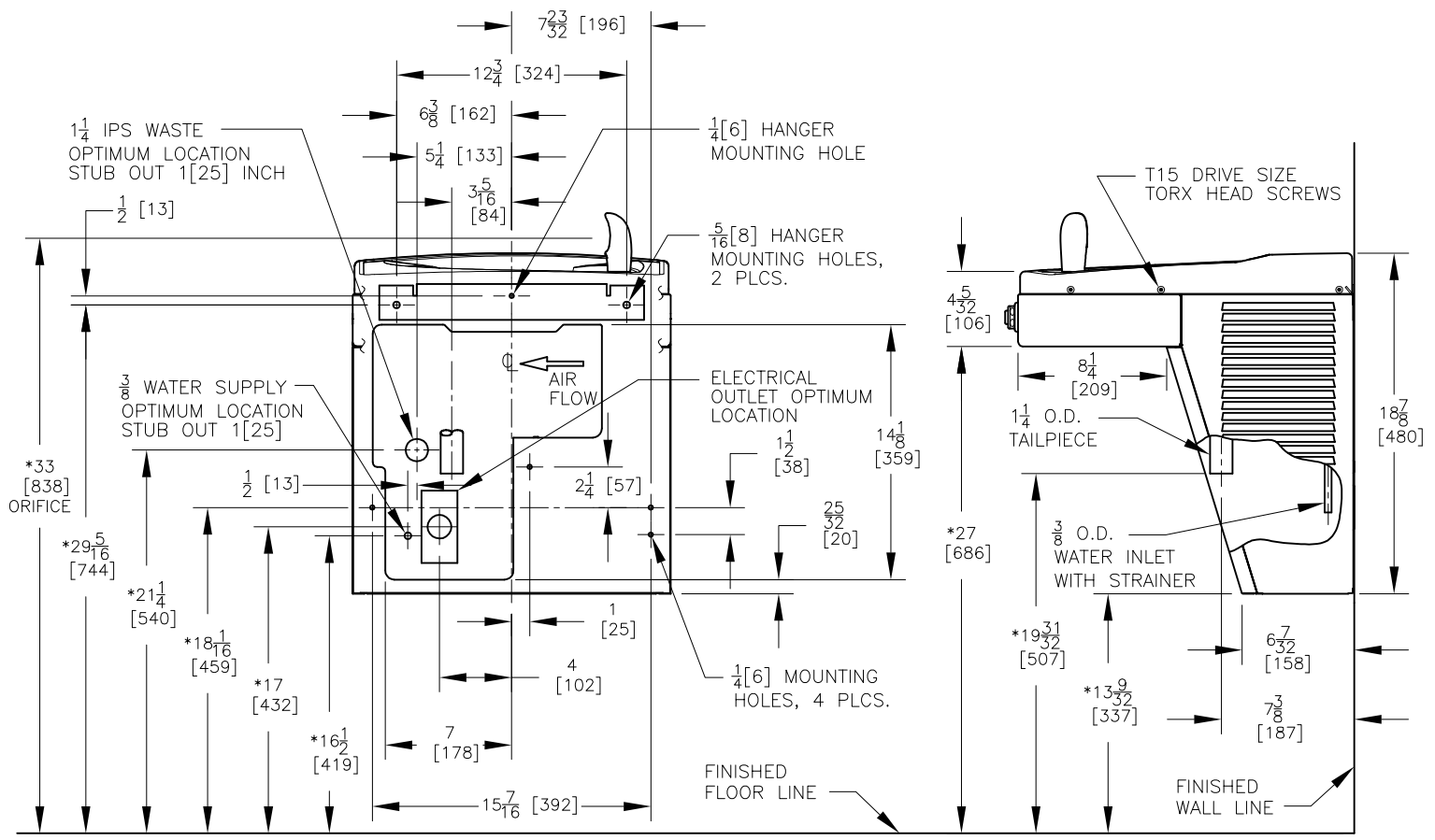

ROUGHING-IN AND DIMENSIONAL DRAWING