

# **NNEBFPG NNFEBFPG with VersaFilter III**

Cooler to Bottle Filler Conversion Kit for OASIS PG8AC  
Coolers

## **INSTALLATION INSTRUCTIONS**

# Section 1: Getting Started

## What's Included:

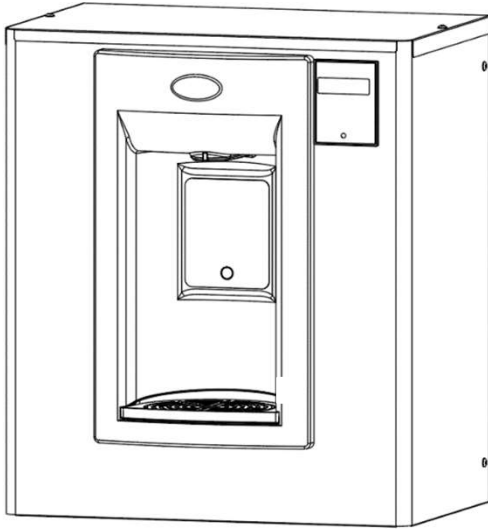

Assembled  
NN(F)EBFPG Cabinet

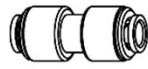

1/4" Union  
x1

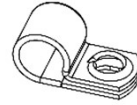

Strain Relief  
P-Clip



10" of 1/4" OD plastic  
tubing with 9" of tubing  
insulation



Installation  
instructions



Drain Elbow  
x2



Side Mounting  
Bracket  
x2

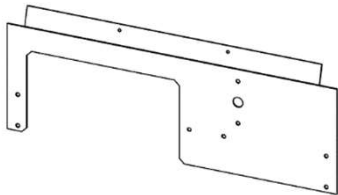

Center Bracket



T15 Torx Screws  
x13



Drainpipe  
x2



#8 Hex Screw

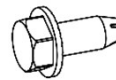

#8 Thread Cutting  
Hex Screw

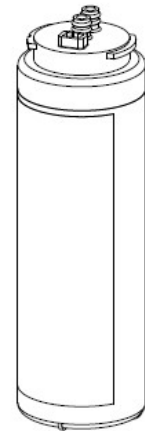

VersaFilter III  
(Model NNFEFPG only)

## Tools & Hardware Required:

- Electric drill/driver
- Small tubing cutter for plastic line
- 1/4" nut driver
- Means to cut 1 1/4" drain pipe
- T15 Torx screwdriver and bit
- 4 appropriate anchors (not supplied)

## Section 2: Single Level Rough-In Drawing

**NNEBFPG:**  
**NNFEBFPG:**

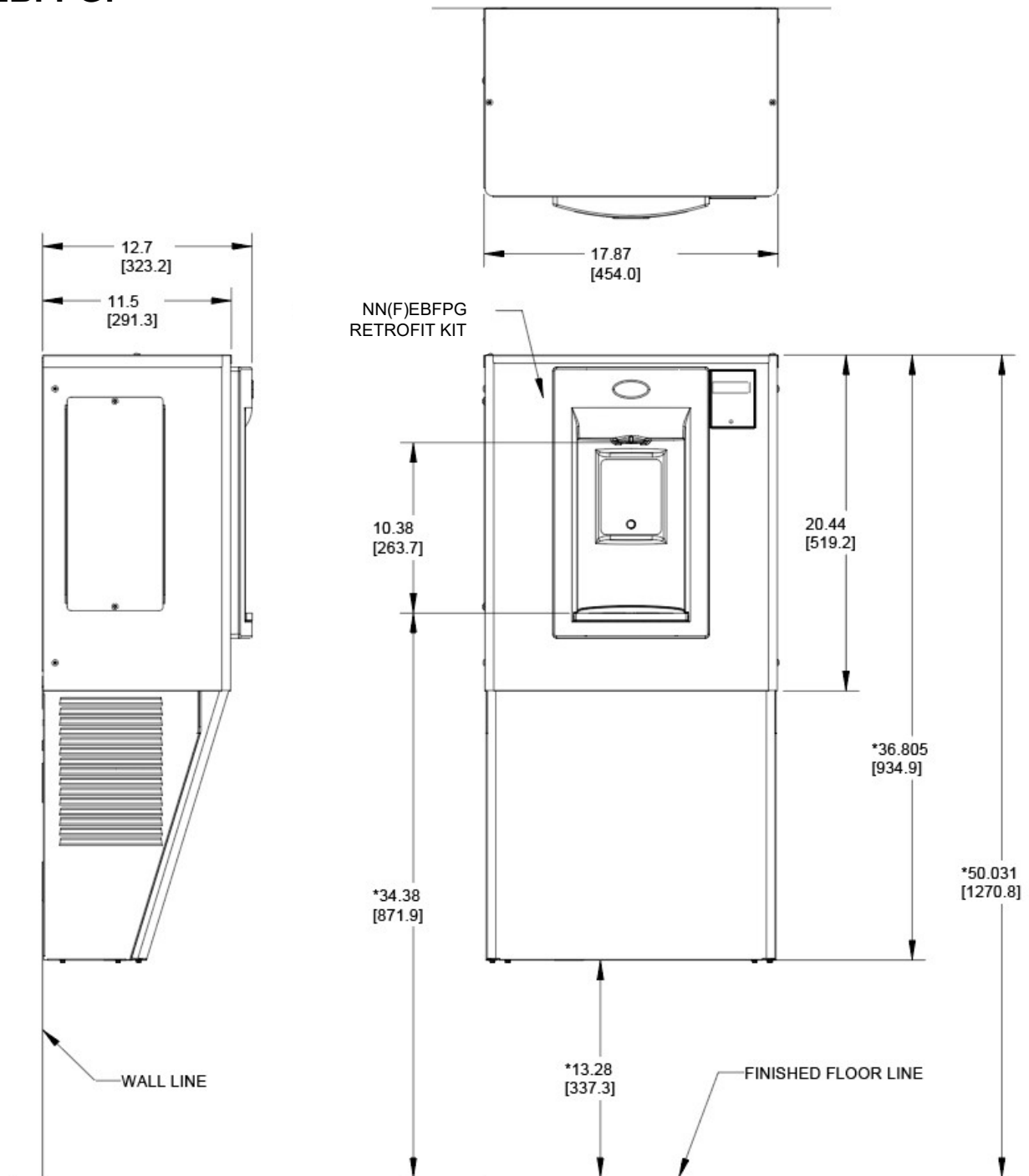

### NOTES:

1. \* DIMENSIONS ARE REFERENCE ONLY.
2. ALL DIMENSIONS ARE IN INCHES.  
DIMENSIONS IN BRACKETS [ ] ARE IN MILLIMETERS.

# PREPARATION

- Disassembly of P8AC Cooler
- Wiring
- Water Lines

## Section 3: Preparation

1. Remove the front panel by removing two Phillips screws under the nose assembly and by loosening the 2x #8 hex screws at the bottom.
2. Turn OFF water supply to the unit. Bleed any remaining pressure from the lines by activating the bubbler valve.
3. Disconnect power by UNPLUGGING the unit.

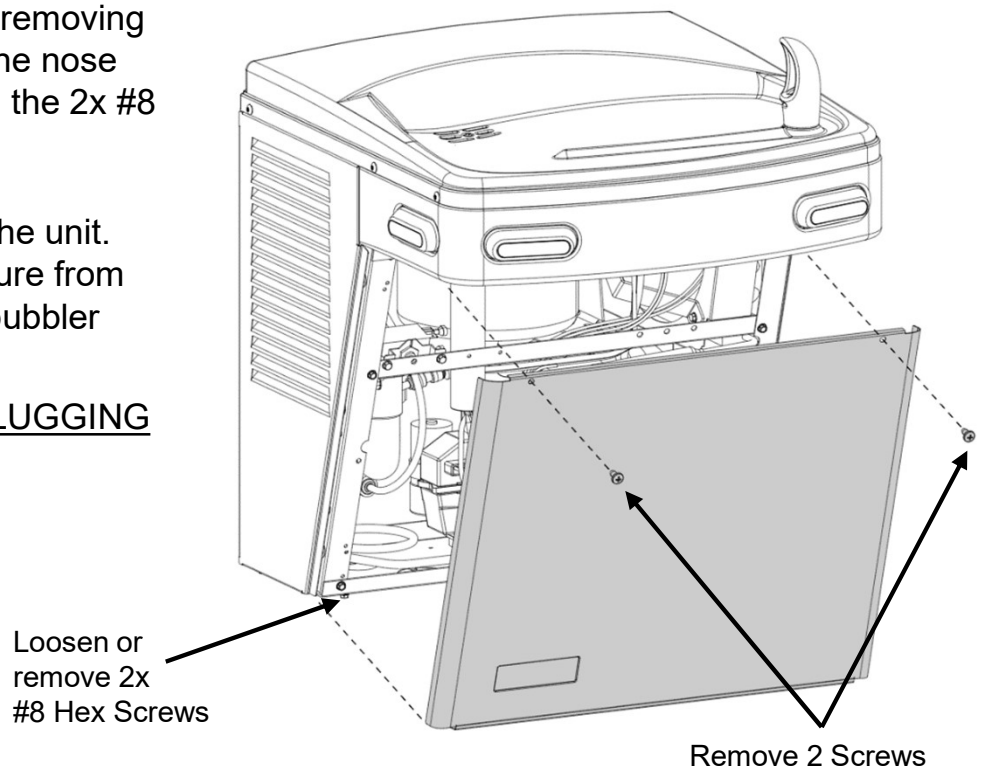

4. Loosen or remove the P-trap so that the fountain nose assembly may be freely removed in the next step.

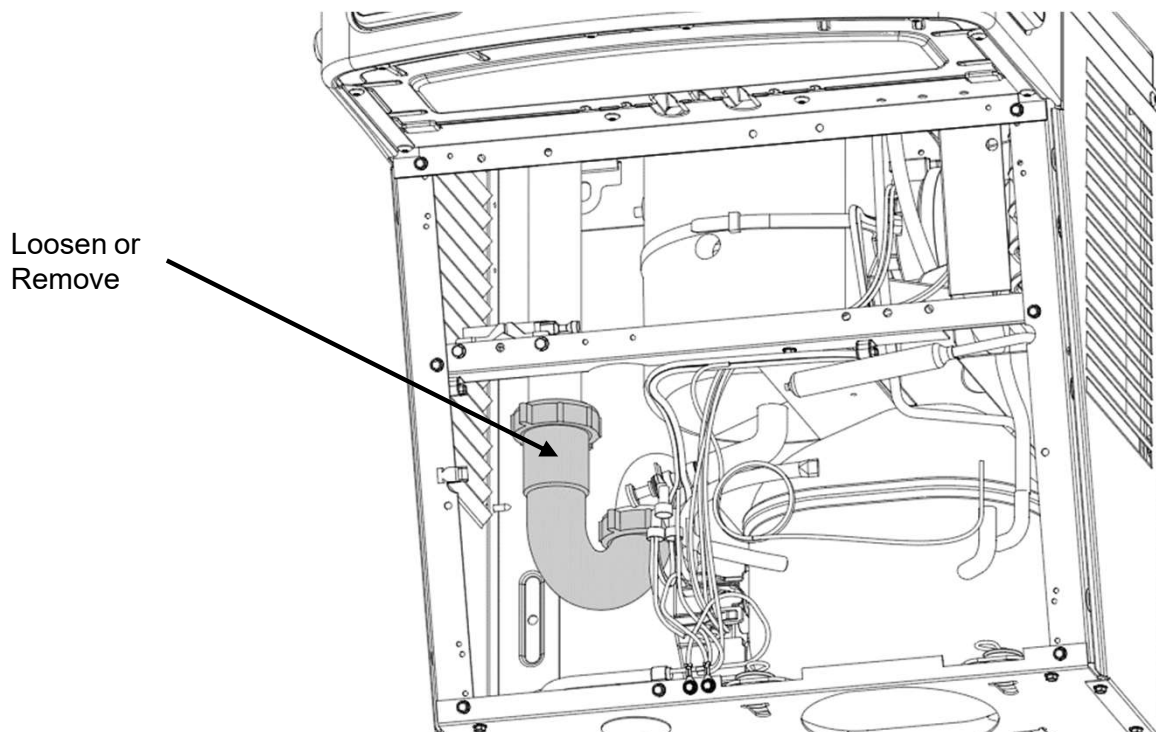

## Section 3: Preparation

5. Remove fountain nose assembly. **Tool: T15 Torx Driver**

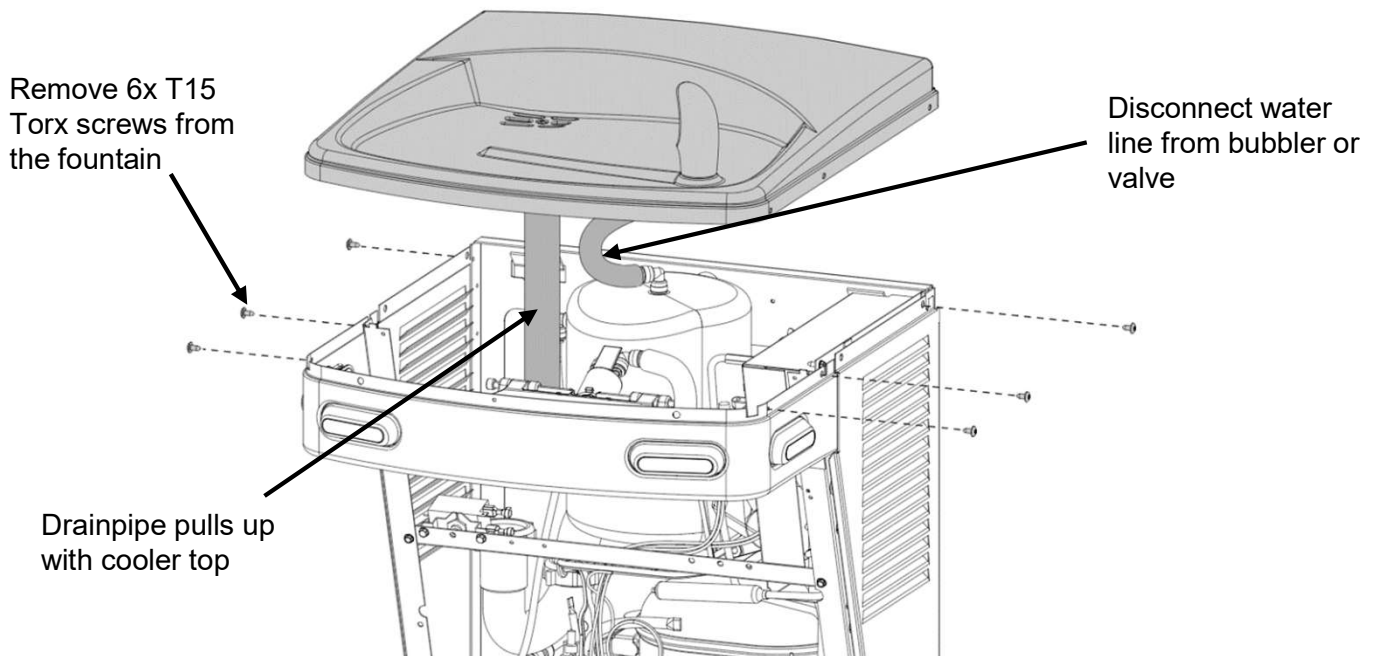

6. Remove the cooler nose assembly. On the Contractor's Choice Model, be sure to carefully remove the cold control. Keep the two cold control assembly screws. **Tool: 1/4" Nut Driver**

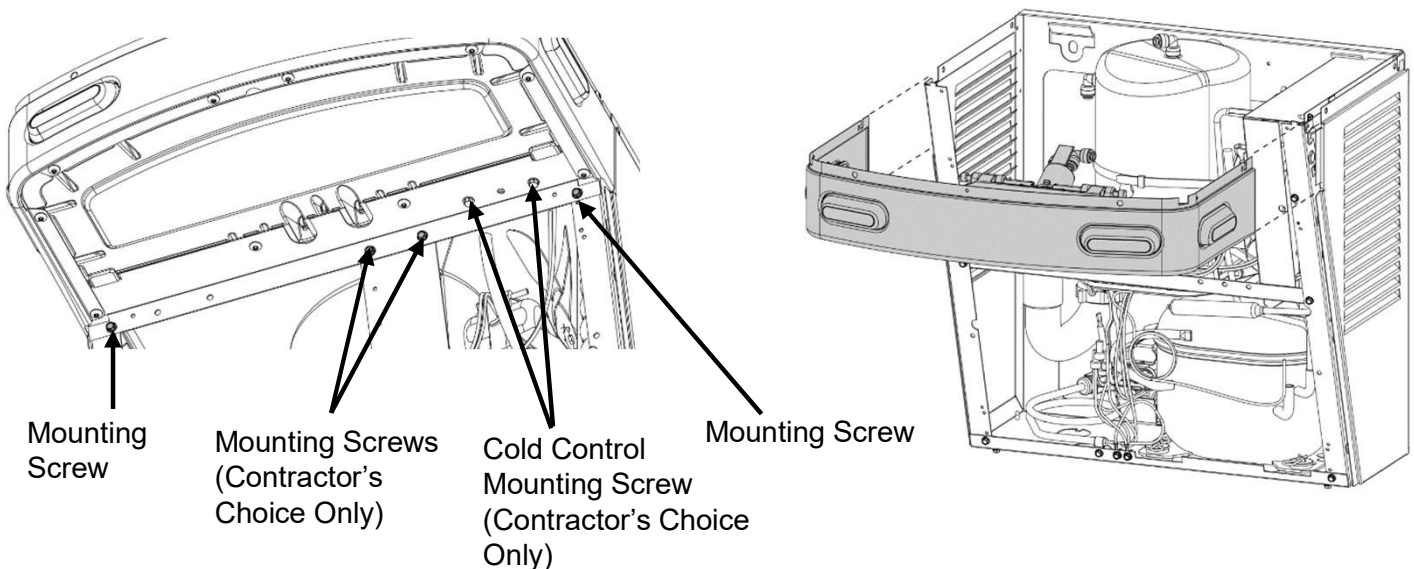

**CONTRACTOR'S CHOICE MODEL:** The cold control will be unsupported at this point. Secure it as necessary and ensure the cap tube does not kink.

## Section 3: Preparation

7. The cooling tank must be pressurized for the NNEBFPG. If the water source line is plumbed directly into the cooling tank, the unit is already pressurized. For the filtered model NNFEBFPG with the Versafilter III move to [Section 3: Step 8](#).

To pressurize the tank, plumb the water source line directly into the cooling tank. Keep the cooling tank water outlet attached to the cooling tank but shift it away from the condenser fan.

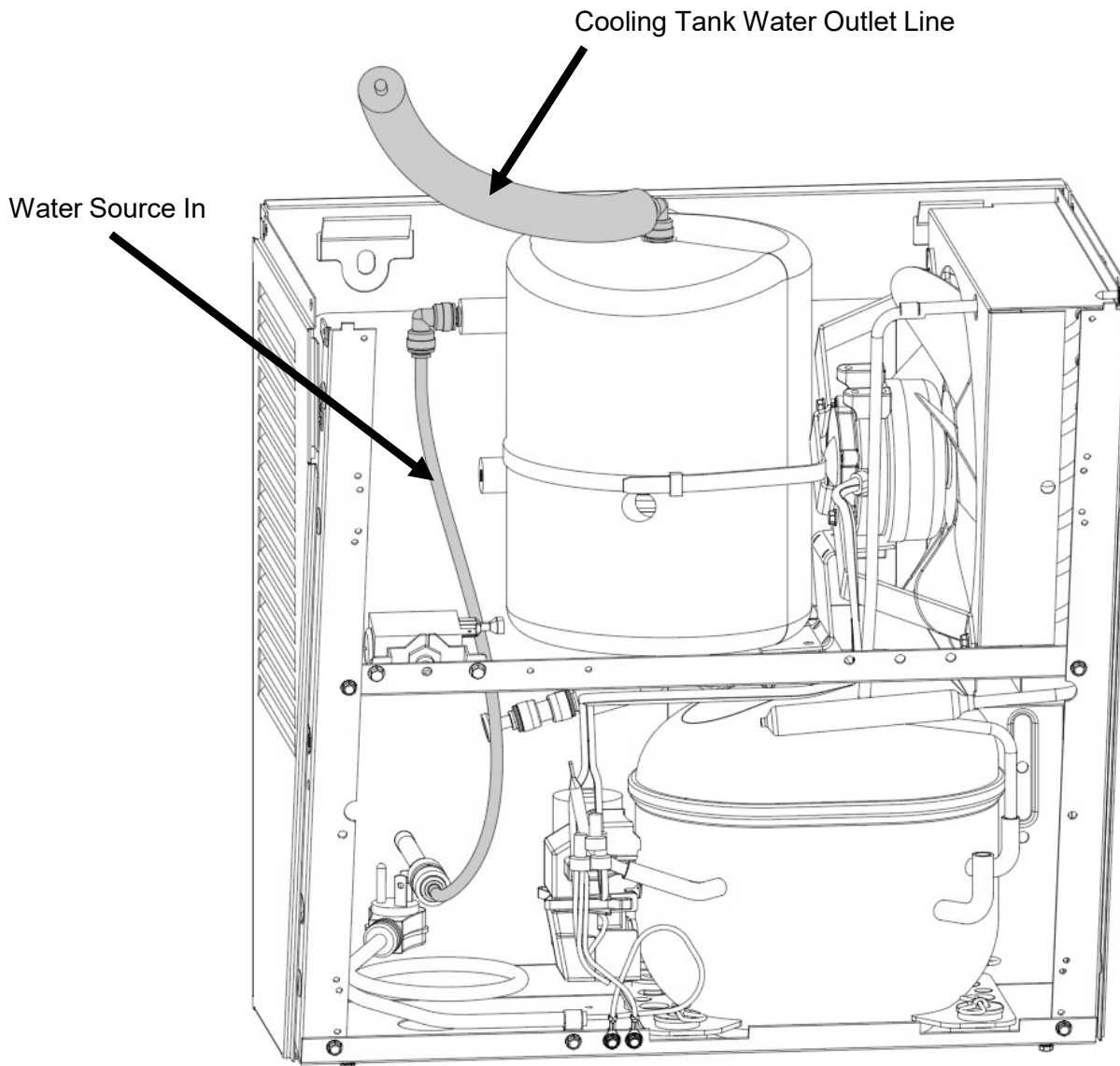

**Shown above is the correct water line orientation**

## Section 3: Preparation

8. Model NNFEBFPG with Versafilter III: Remove the 1/4"OD water source line plumbed directly into the cooling tank or plumbed directly to the cartridge valve on the cooler nose assembly removed in [Section 3: Step 6](#).
9. Keep the cooling tank water outlet line attached to the cooling tank but shift it away from the condenser fan.

In future steps after the NNFEBFPG frame assembly is installed the Inlet Line on the Versafilter III head assembly will be connected to the Water Source Reducing Fitting and the Outlet Line on the head assembly will be connected to the Cooling Tank Water Inlet Fitting.

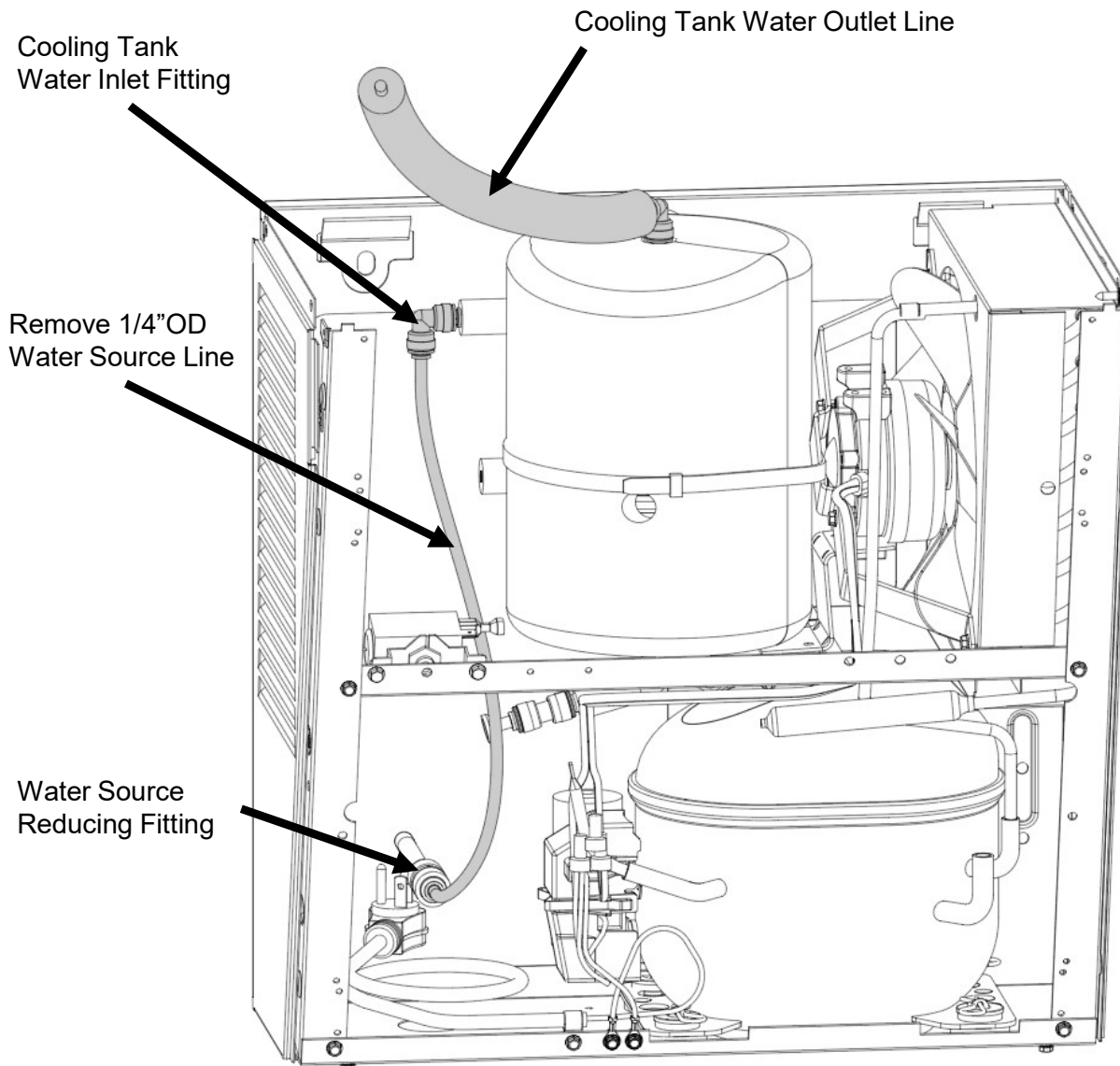

**Shown above is the correct water line orientation**



# **SINGLE LEVEL INSTALLATION**

- **Assembly of NNEBFPG & NNFEBFPG Cabinet**
- **Wiring**
- **Plumbing**

## Section 4: Installation

1. The NNEBFPG and the NNFEBFPG comes partially assembled for shipping. Remove the kit from the packaging and separate it into the assemblies and components shown below.

**Tool Needed: T15 Torx bit**

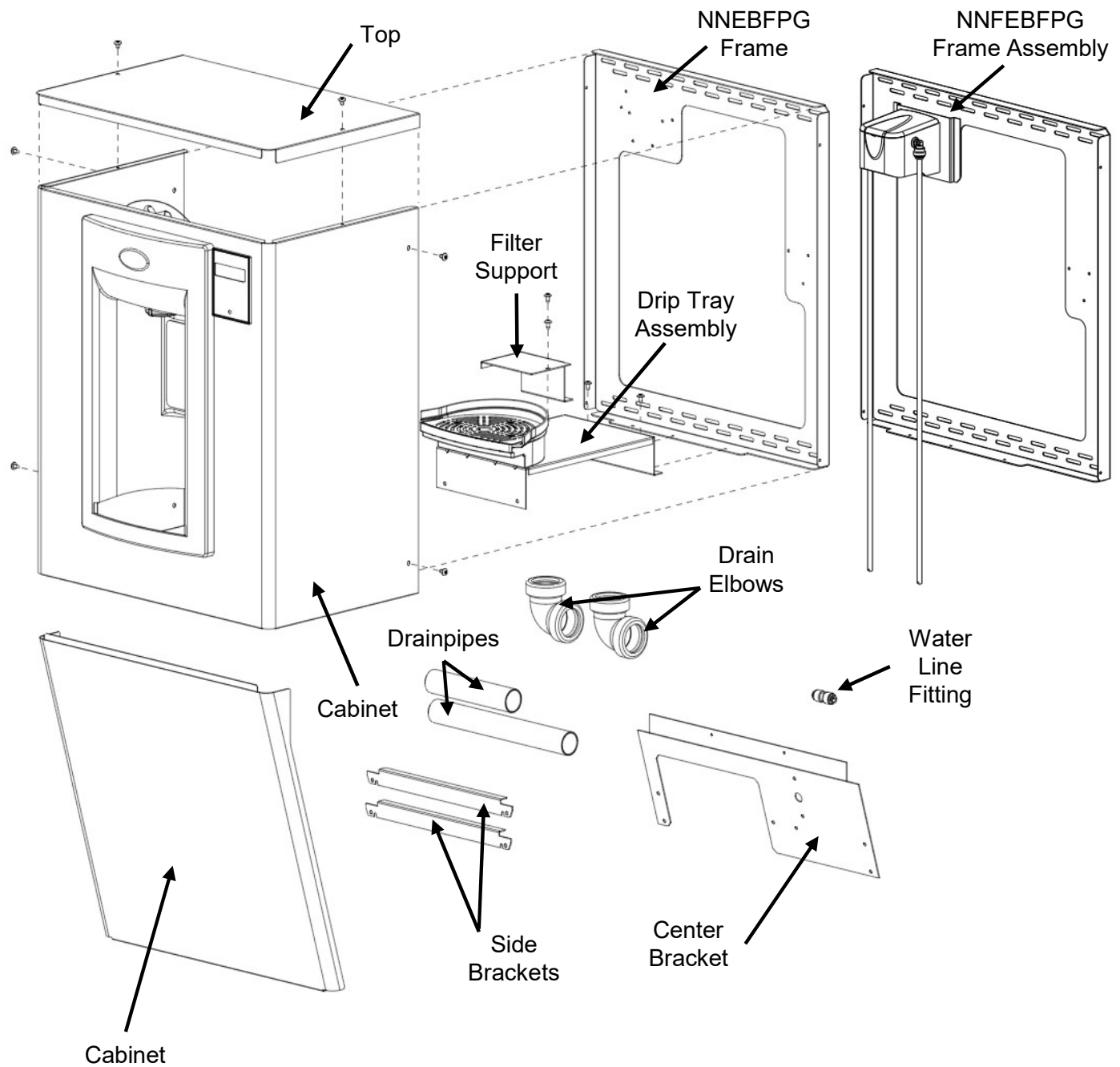

## Section 4: Installation

2. Assemble the center bracket to the holes in each of the cooler struts with 4x T15 Torx screws.

**Original P8AC Model: DO NOT RELOCATE COLD CONTROL ON THIS MODEL**

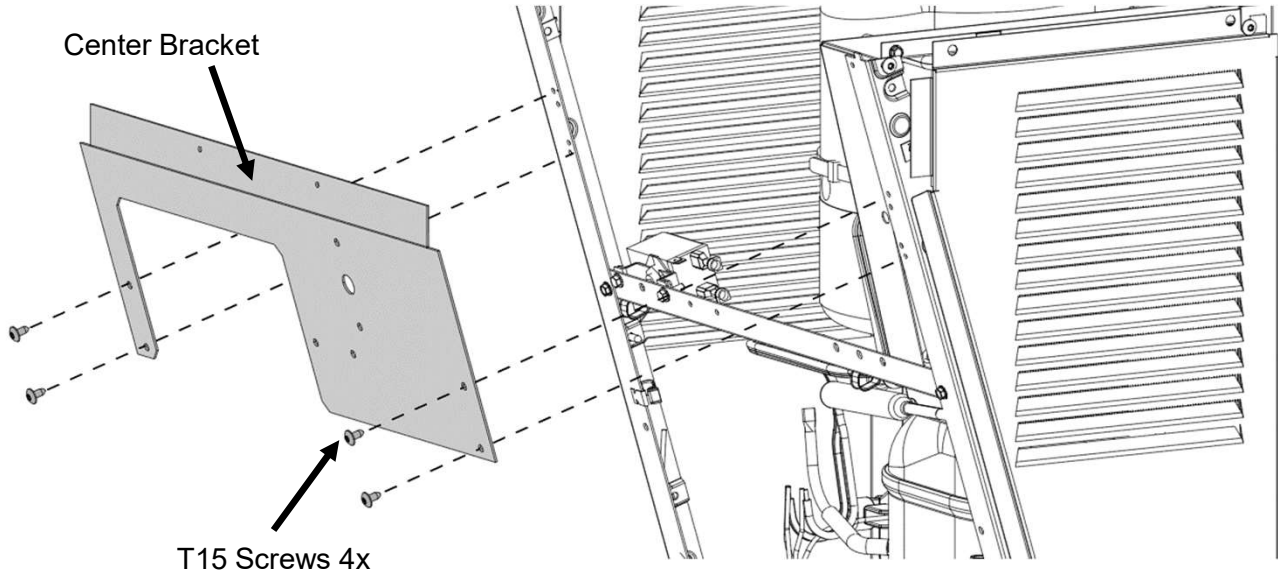

### Contractor's Choice Model:

After affixing the center bracket to the cooler, assemble the cold control to the center bracket using the original machine thread screws that were on the unit. Assemble the fan bracket to the center bracket with the original 1/4" drive screws.

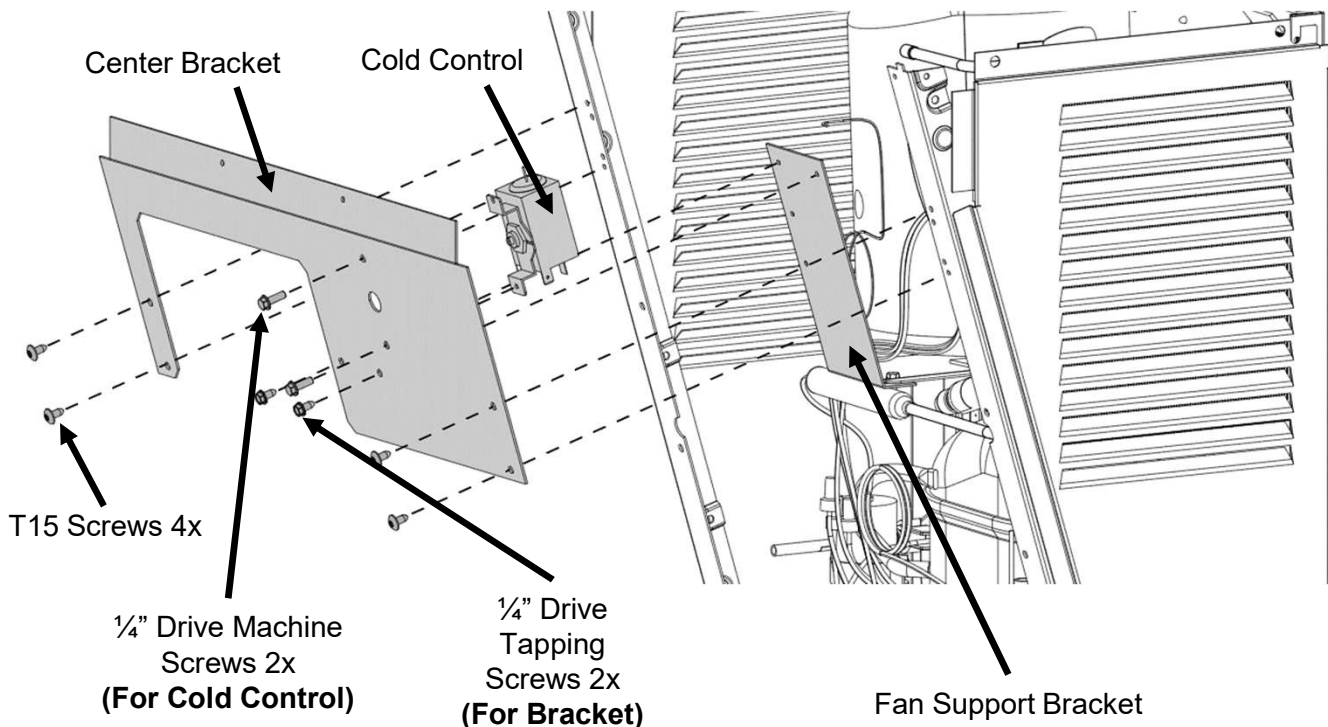

## Section 4: Installation

3. Assemble the two side brackets to the unit with two T15 Torx screws each. The brackets are identical and will work on both sides of the unit.

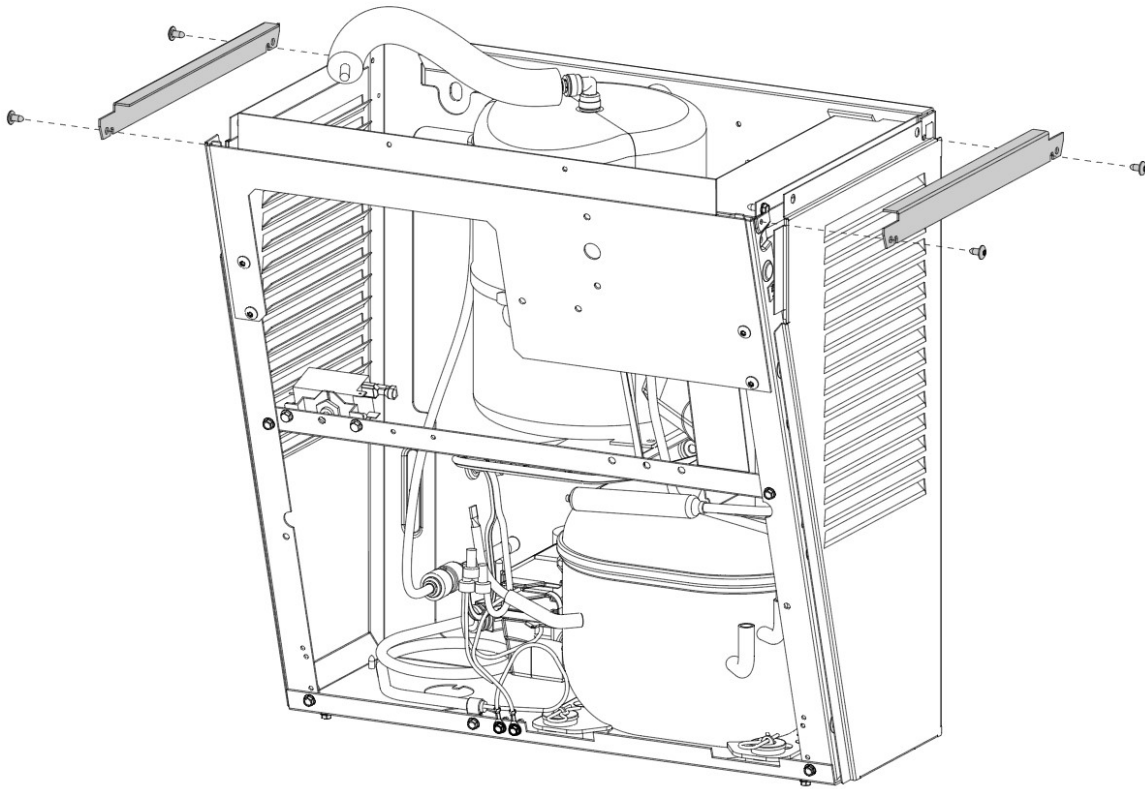

Align each bracket as shown. Use the clearance hole to attach the screw in the cooler strut (away from the wall) and use the slot to attach the bracket in the rear (closer to wall).

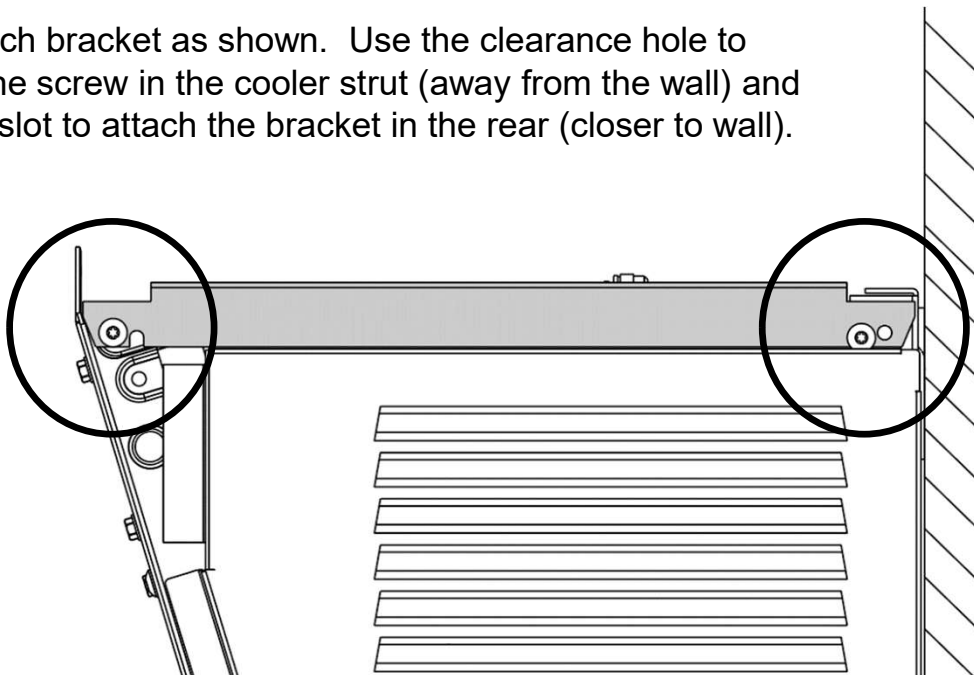

## Section 4: Installation

- Without taking the cooler off the wall, place the retrofit frame against the wall and set it onto the top flange of the cooler frame.

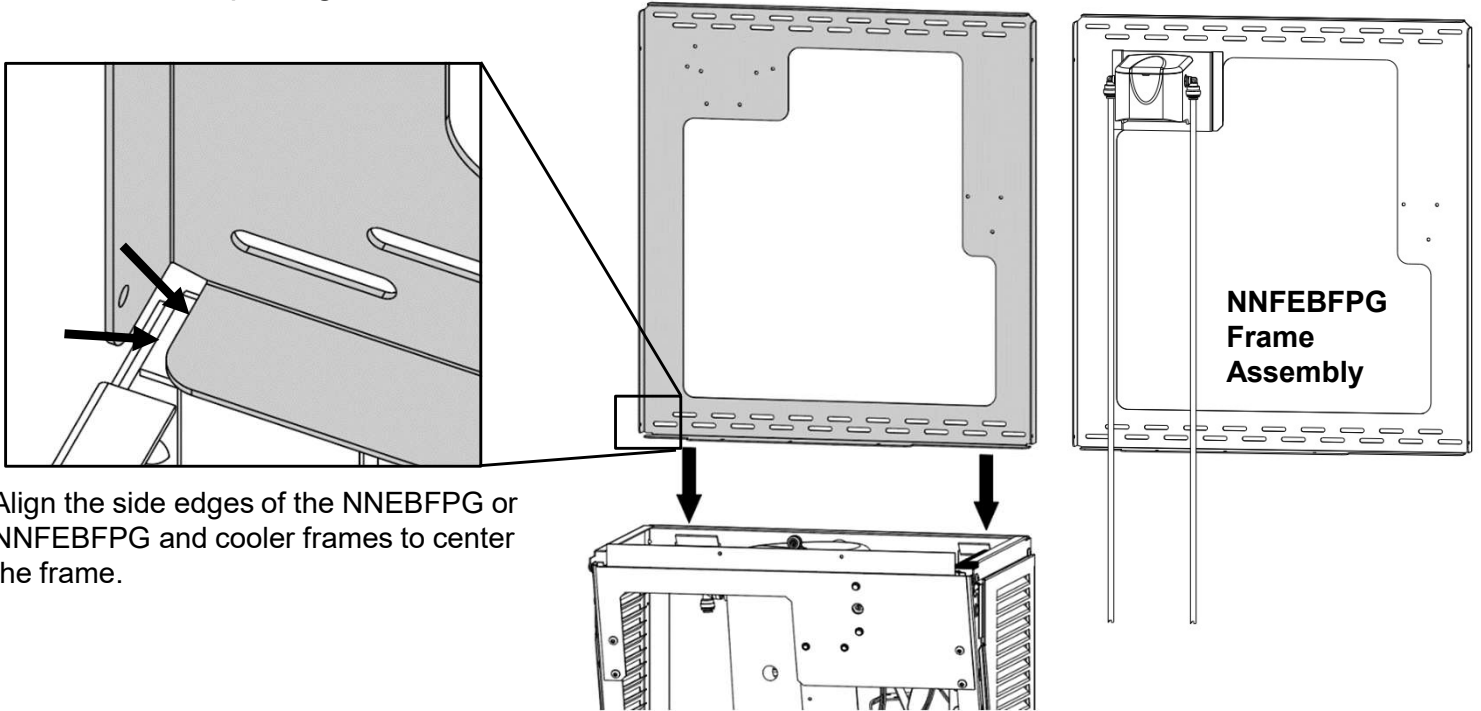

- Affix the frame to the wall with at least 4 anchors into any appropriate anchor points through the staggered slotted holes. **Be careful to ensure the frame stays centered on the cooler frame.**

Choose a minimum of 4 anchors appropriate for the surface the unit is being mounted to. Anchors are not provided.

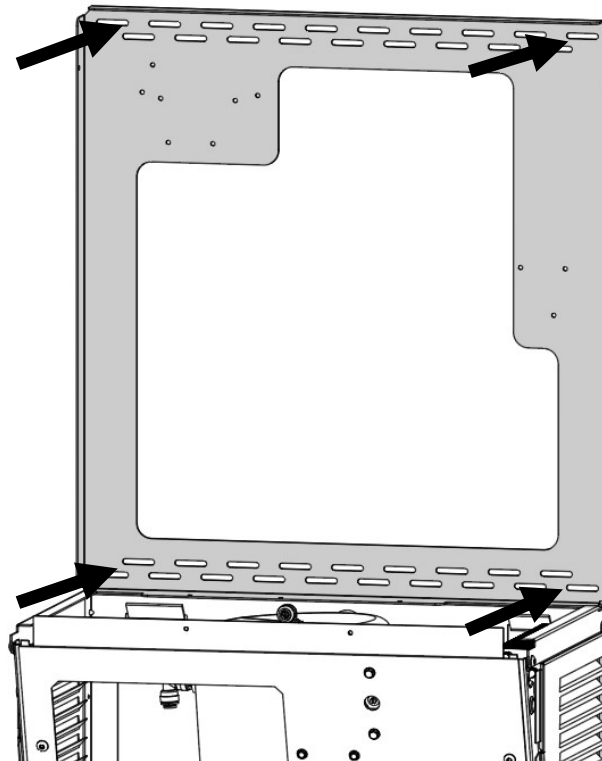

## Section 4: Installation

6. With 4x T15 Torx screws, assemble the drip tray assembly to the center bracket and wall frame.

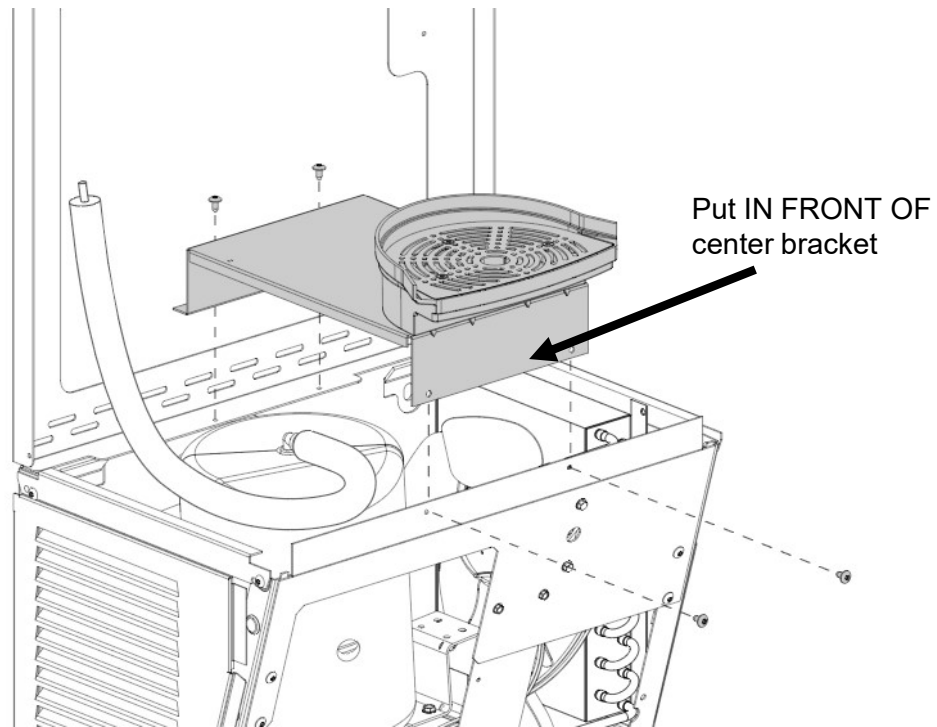

7. Attach the filter support bracket with 2x T15 Torx screws to the frame and drip tray support bracket. This bracket helps to prevent the filter cartridge from falling into the cooler unit below during installation or replacement.

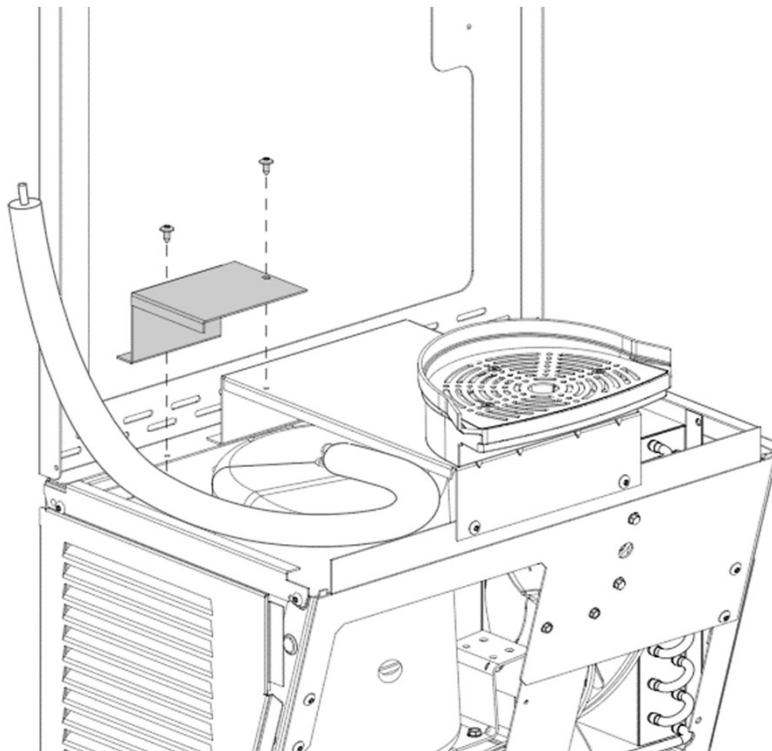

## Section 4: Installation

8. NNFEBFPG with Versafilter III only: Insert Filter Head Inlet Tube into water supply reducing fitting. Install VersaFilter III filter cartridge to Filter Head Assembly. See instructions on filter cartridge for Installation Instructions and for Filter Flushing Instructions. Direct Filter Head Outlet Tube to a container to collect water for flushing the filter. Turn on water. Flush till water is clear. When flushing is complete, insert Filter Head Outlet Tube into cooling tank inlet fitting. Cut tubing if necessary.

### Model NNFEBFPG

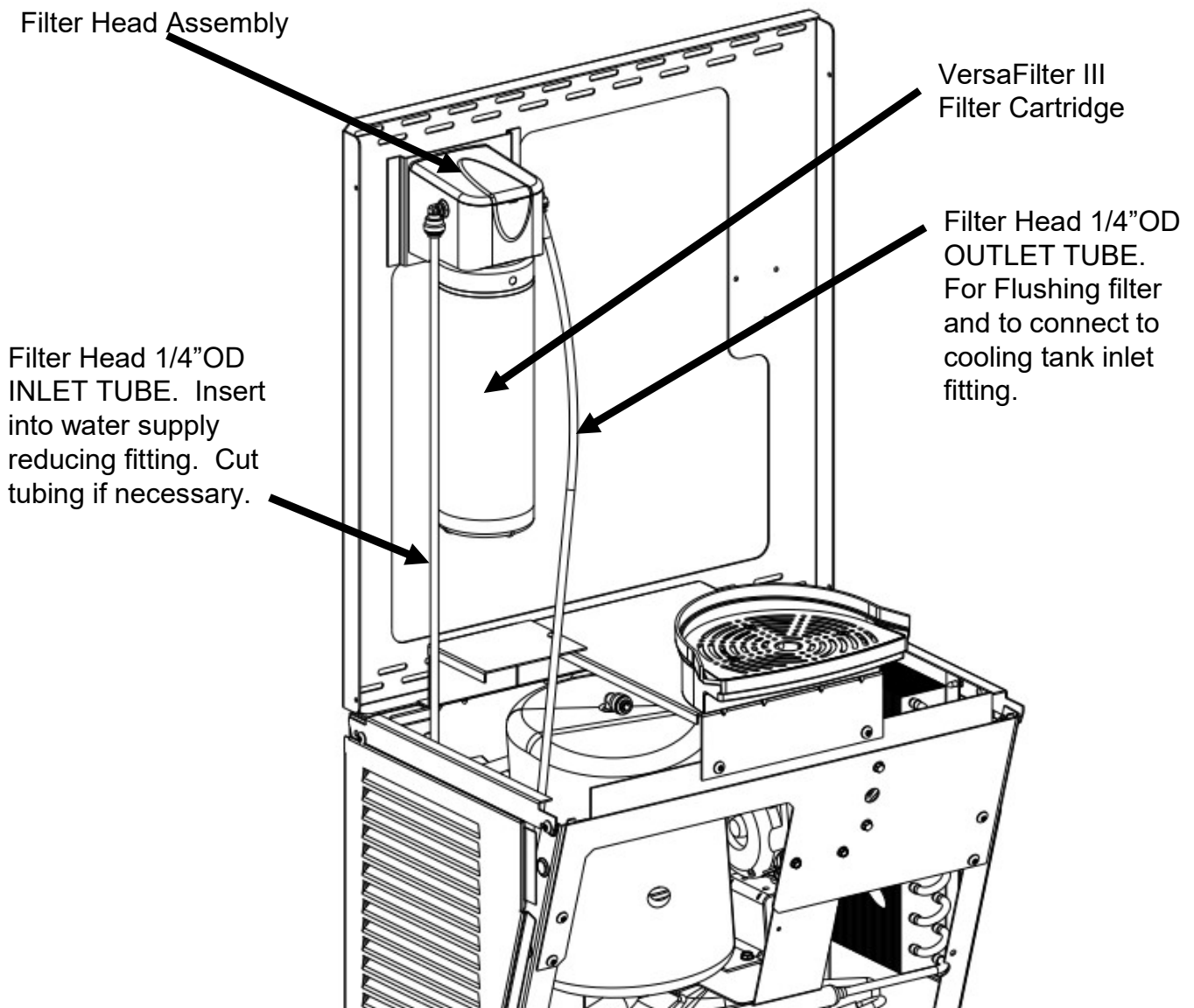

## Section 4: Installation

9. Attach one of the drain elbows to the drip tray stem. Insert the drainpipe provided into the elbow and then attach another elbow onto the pipe. Use the remaining drainpipe and connect the drip tray drainage system to the installed P-trap.

**NOTE: Drainpipes will need to be positioned and cut to length as needed.**

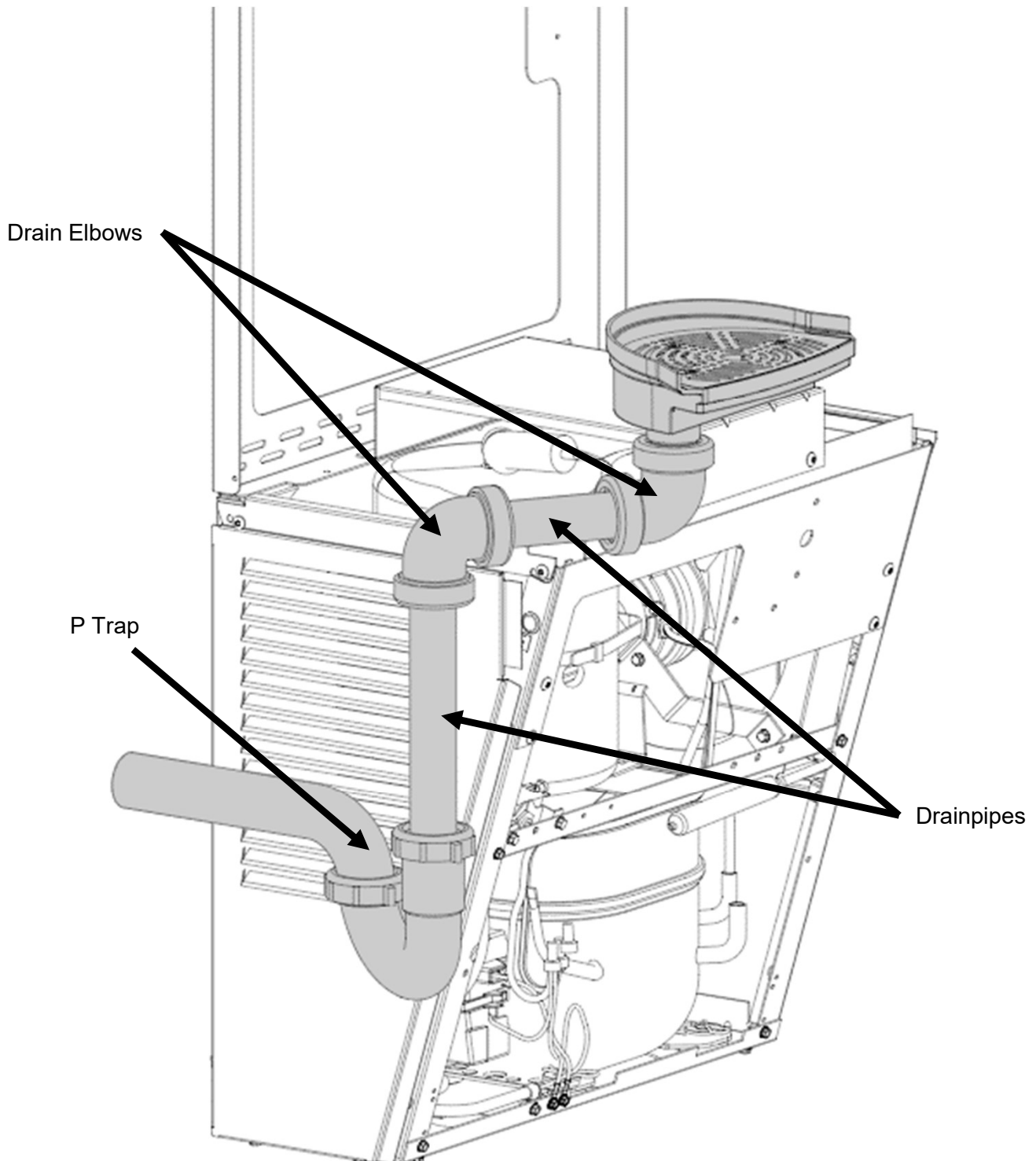



## Section 4: Installation

10. Assemble NNEBFPG or NNFEBFPG wrapper to the installed frame. Rest the alcove on the drip tray and ensure the wrapper walls rest OUTSIDE of the frame and side brackets.

**NOTE:** The drip tray will hold the weight of the wrapper but it is recommended to keep a hold on the unit during installation for safety.

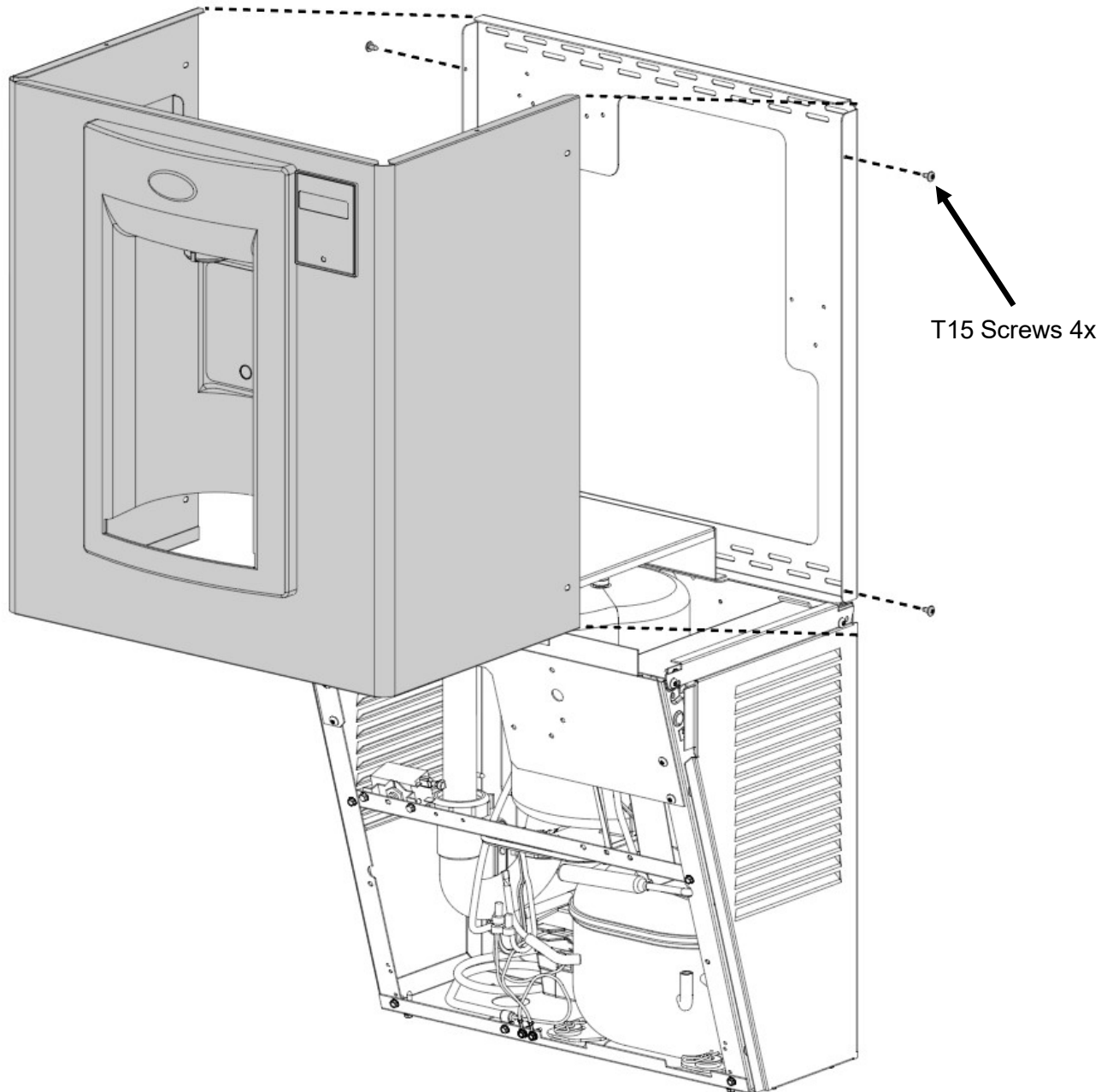

## Section 4: Installation

11. If the outer edge of the drip tray is not properly aligned, loosen the screws mounting the filter support and drip tray bracket to the frame and push forward or back as needed. Then retighten the screws.

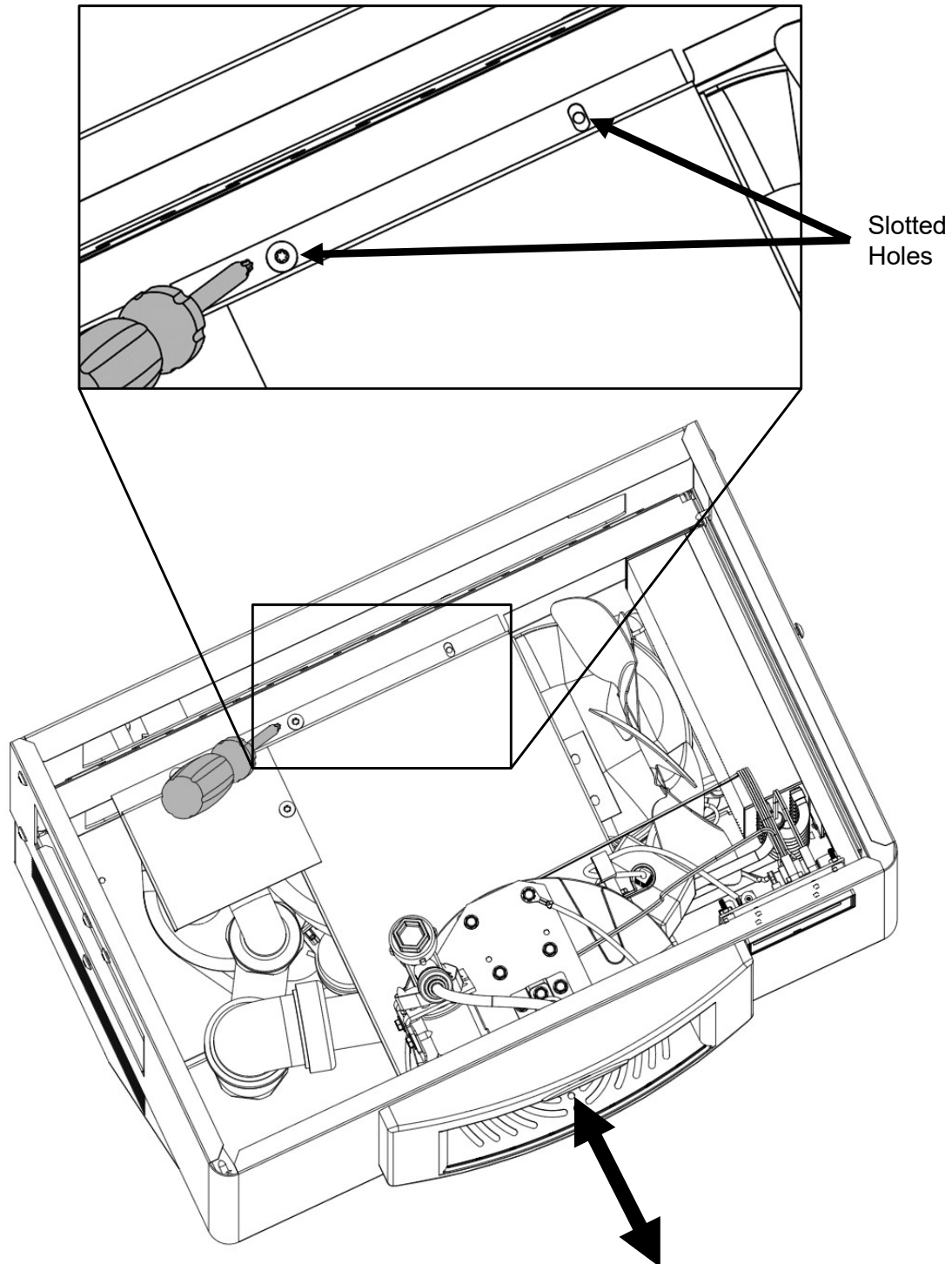

## Section 4: Installation

12. Attach the ¼" union fitting to the Cooling Tank water outlet line.

13. Attach one end of the provided ¼" water line with insulation tubing to the solenoid valve located on the alcove, and the other end to the ¼" union fitting. Cut provided water line and insulation tubing as needed.

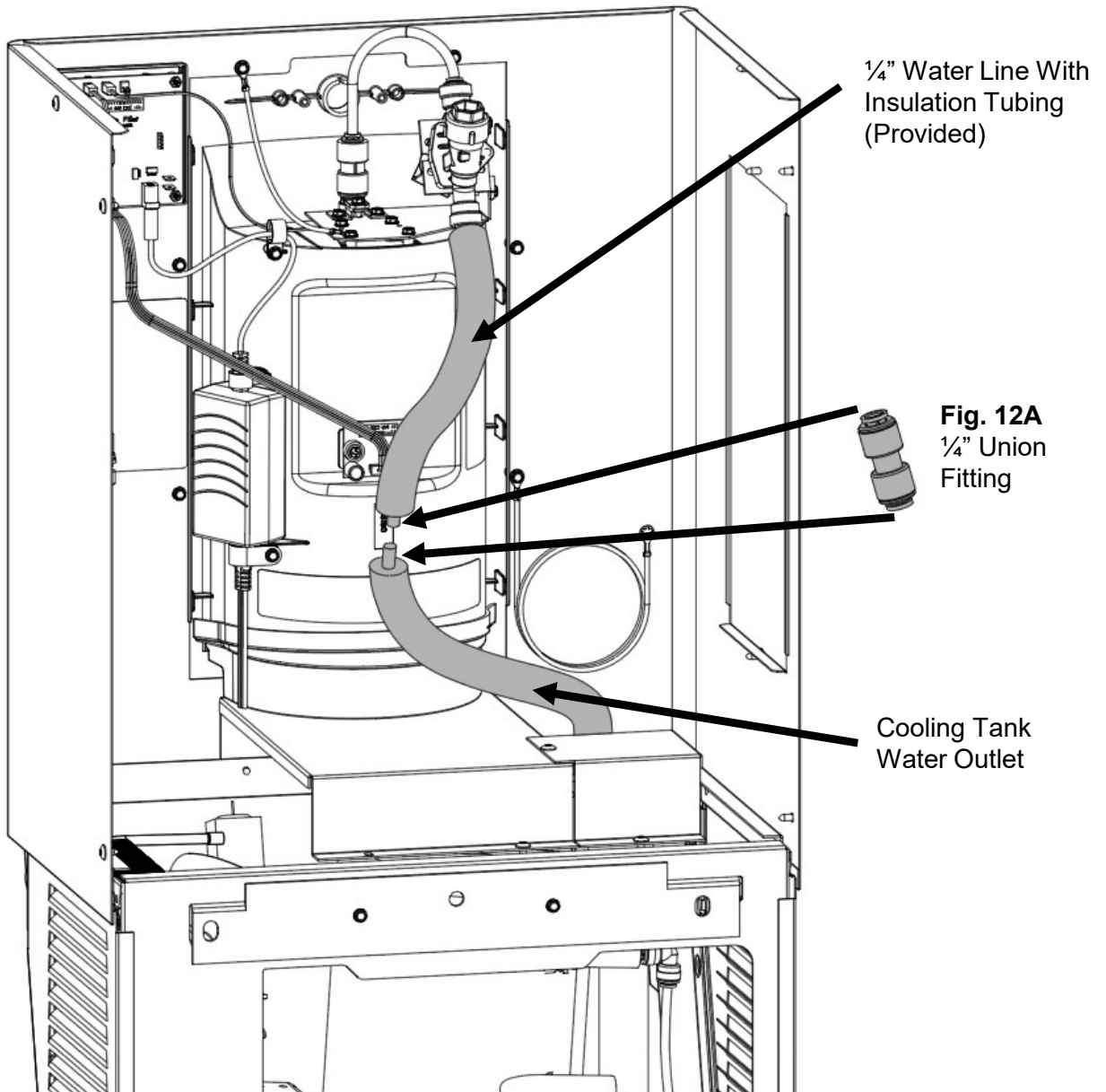

## Section 4: Installation

14. Install the strain relieving P-Clip roughly 36" from the three-prong wall plug and attach to the fountain strut with the provided #8 Hex, tapping screw. Use the clearance hole shown in the image below.
15. Attach the ground ring terminal using the provided thread cutting machine screw to an available hole on the fountain strut.
16. Connect one of the IEC connectors to the power brick behind the alcove of the bottle filler. Ensure that the free IEC connect does not become an obstruction.

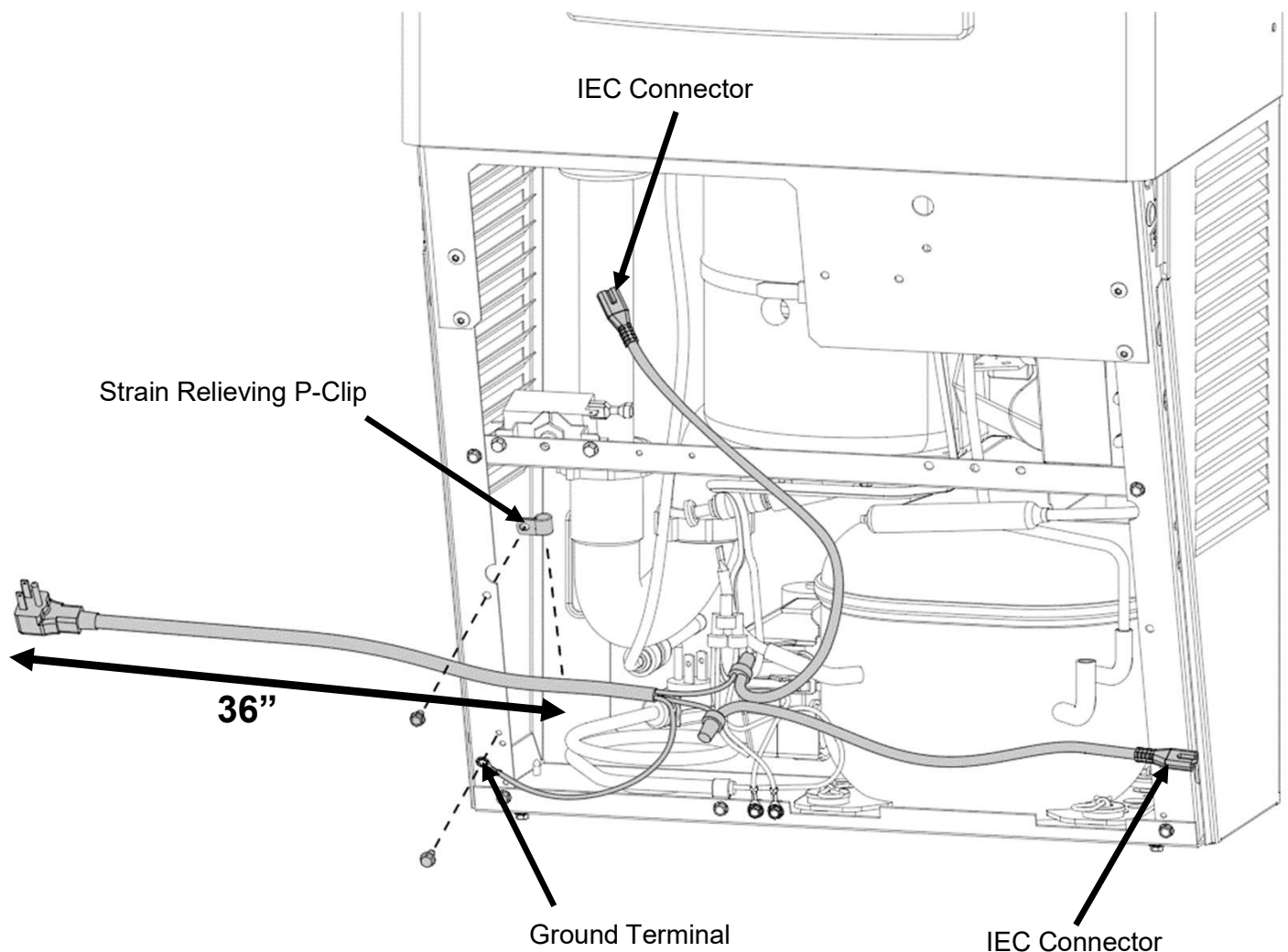

## Section 4: Installation

17. Complete the installation by turning on the water source and checking for leaks.
18. Ensure nothing is obstructing the fan blade. Plug the power cord back into the wall outlet and then test to ensure the bottle filler is functioning properly.
19. Once the unit has been verified to be functioning properly, install the front cover panel by inserting the top flange up between the wrapper and center bracket, then tipping the panel back to the fountain. Secure it with the 2x #8 hex screws at the base of the unit (refer to Step 3, page 5),

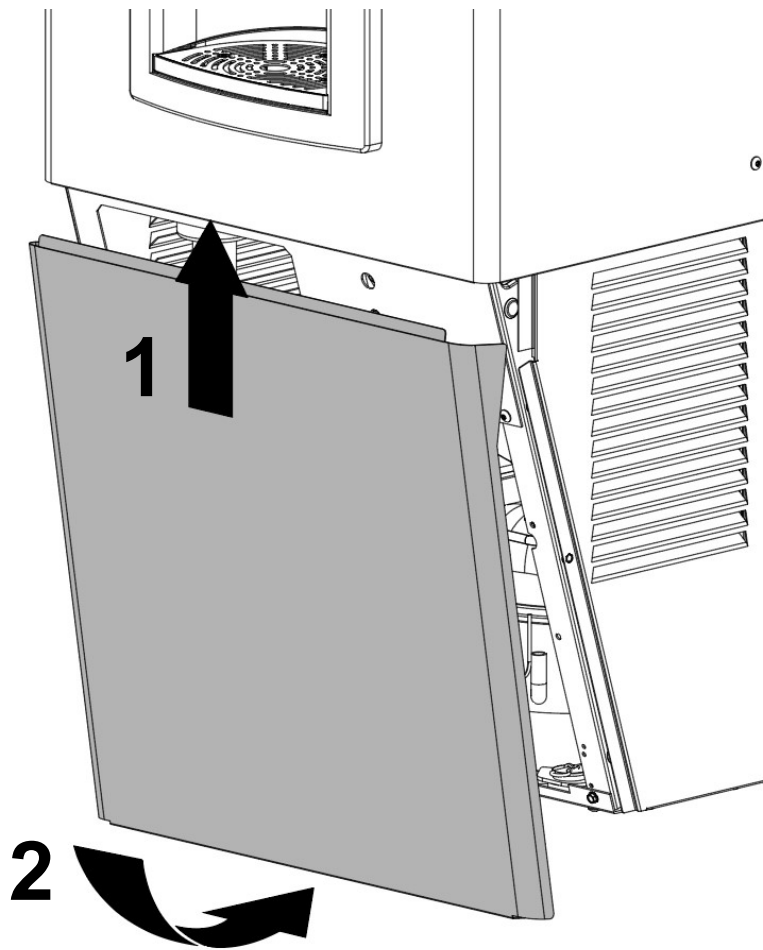

Complete the installation by installing the Top and filter access panels.

# **SPLIT LEVEL INSTALLATION**

- **Assembly of NNEBFPG and NNFEBFPG Cabinet**
- **Wiring**
- **Plumbing**

# Section 5: Split Level Rough-In Drawing

## NNEBFPG: NNFEBFPG Option:

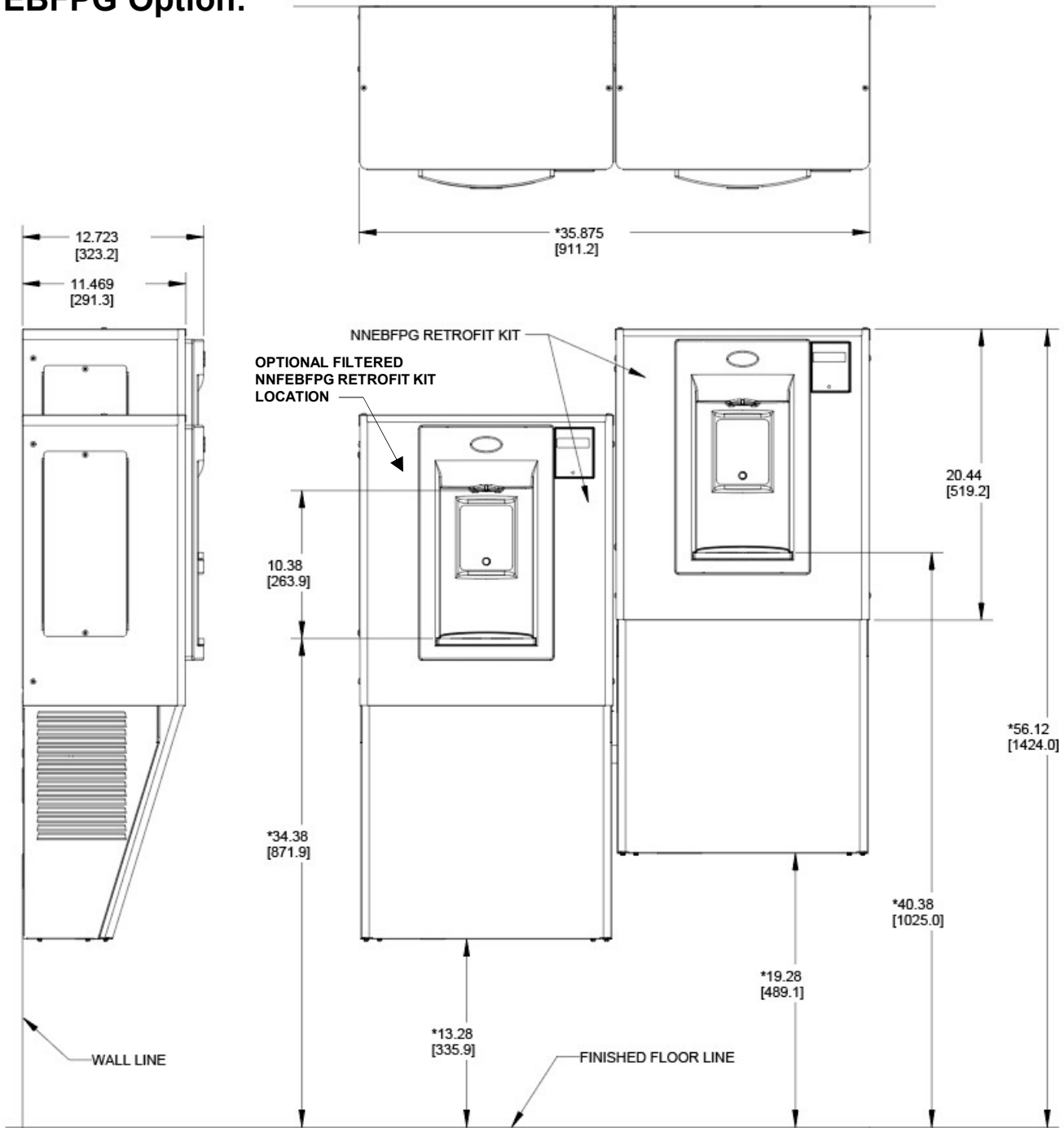

### NOTES:

1. \* DIMENSIONS ARE REFERENCE ONLY.
2. ALL DIMENSIONS ARE IN INCHES.  
DIMENSIONS IN BRACKETS [ ] ARE IN MILLIMETERS.

## Section 6: Split Level Installation

1. Remove the fountain wrappers and nose assembly from each unit (refer to **pages 5-6**) to prepare the units for the NNEBFPG or the NNFEBFPG installation. Unplug the fountain unit and shut off their water source.
2. Remove the drainpipes between the units but do not remove the p-trap.
3. The split level fountain cooling tank is already pressurized. Disconnect the water source line so that the two units are no longer connected. **Ensure the water source is turned off prior to this step.**

**Note: Have a water collection container ready to drain water from the lines.**

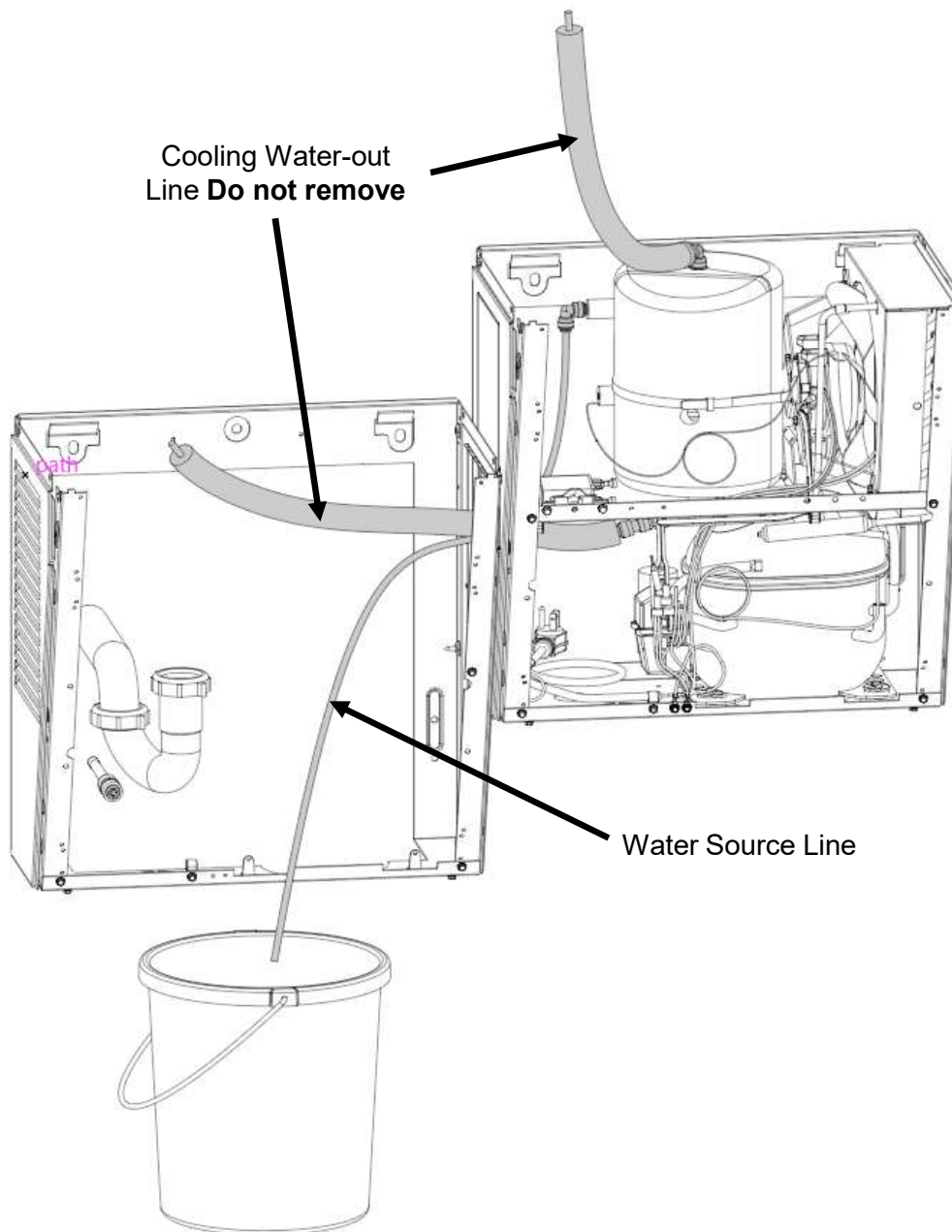



## Section 6: Split Level Installation

4. Take one of the NNEBFPG frames and center it on the dummy unit frame. Mark 4 appropriate holes for your chosen wall anchors (not provided) and then remove the frame to pre-drill the anchor points.

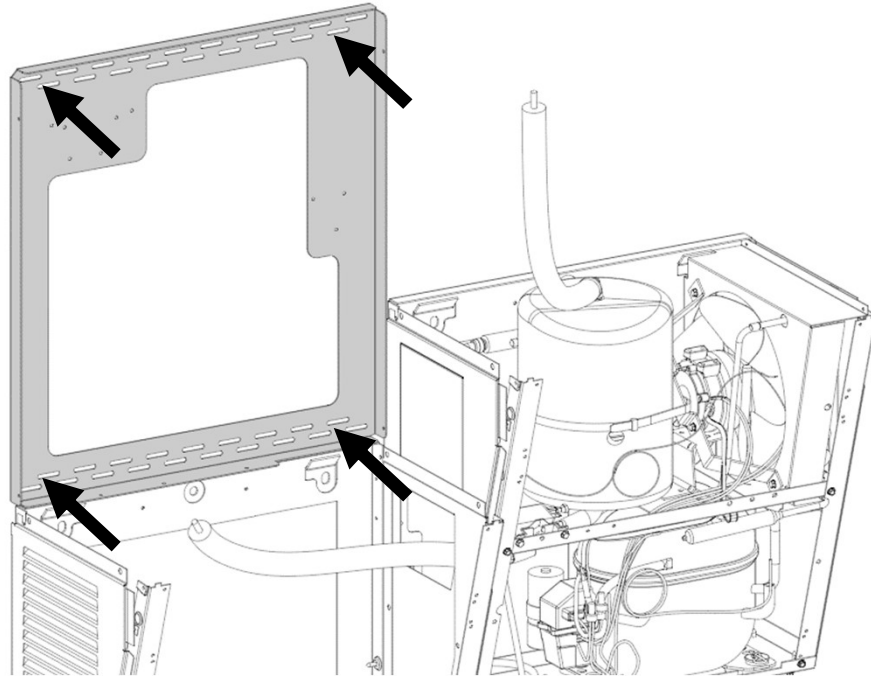

5. After the holes have been drilled, remove the dummy unit from the wall but **do not remove** the hanging bracket.

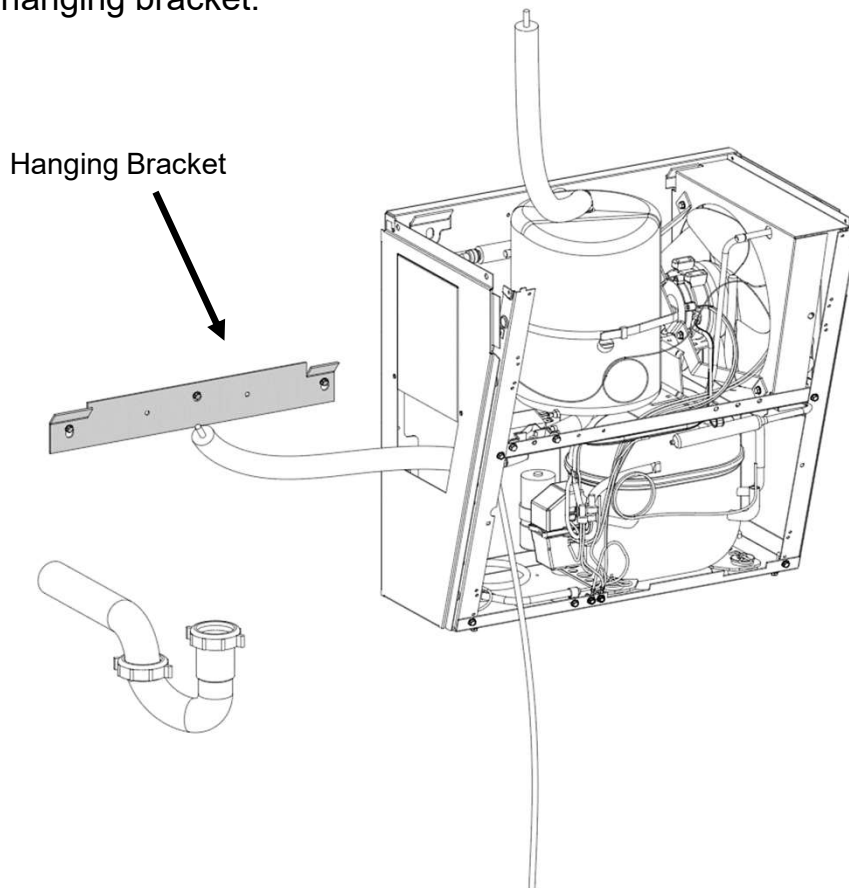

## Section 6: Split Level Installation

6. Follow the steps on **pages 10-18** and assemble the NNEBFPG kit to the **refrigerated side first**. Do not yet fully install the drainpipes and do not install the power cord.
7. While the dummy unit is still off the wall, install the center and side brackets from the second NNEBFPG or the NNFEBFPG kit to the dummy unit frame. **Refer to pages 11-12.**

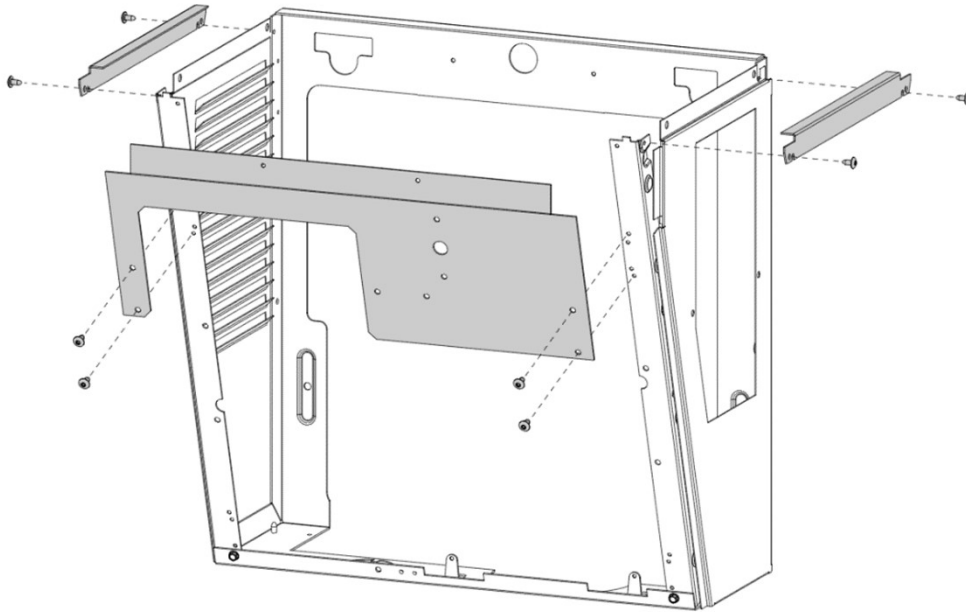

8. Lay the dummy unit on the floor and set the NNEBFPG frame or the NNFEBFPG frame assembly onto the unit and then install the drip tray bracket assembly with the T15 Torx screws provided. **Refer to page 14.**

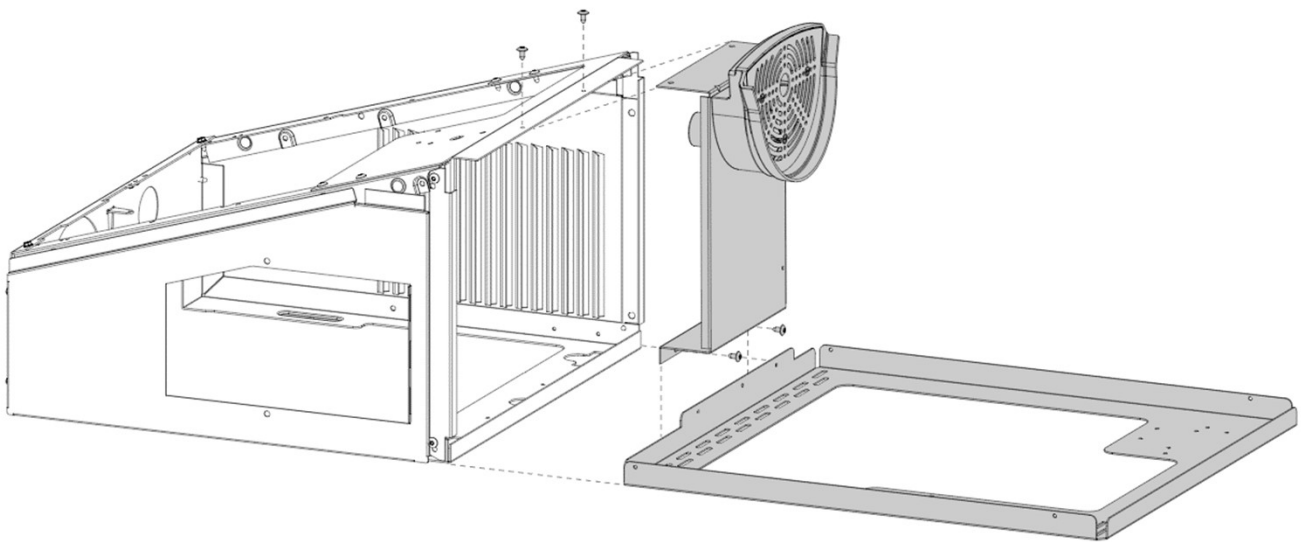

## Section 6: Split Level Installation

9. Remove the top panel from the NNEBFPG or NNFEBFPG wrapper assembly and lay the wrapper over the assembled frame and drip tray. Secure with 4x T15 Torx screws provided. Refer to **page 17**.

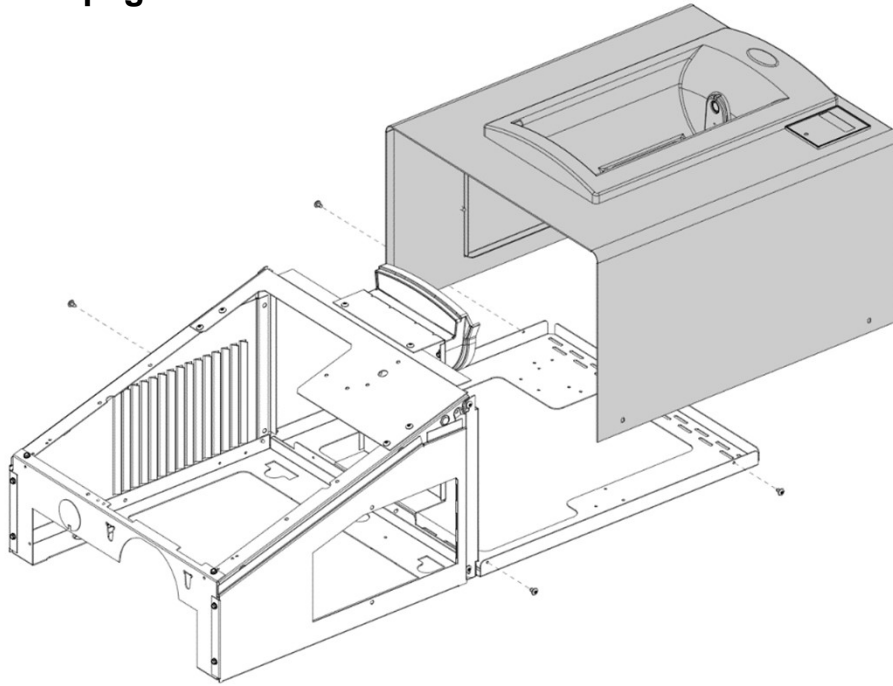

10. Carefully lift the assembled dummy unit by taking hold of the fountain frame and NNEBFPG or NNFEBFPG kit. Hang the assembly back on the vacant wall hanging bracket.

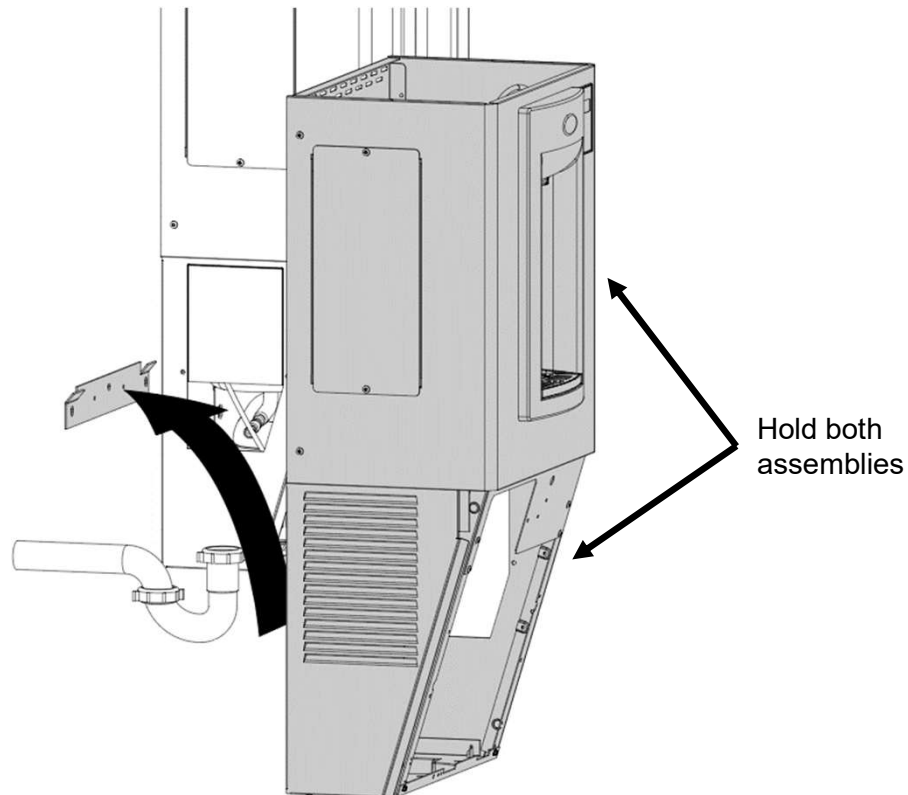

## Section 6: Split Level Installation

11. Ensure that the frame and fountain are flat against the wall and install your 4 chosen wall anchors (not supplied) to secure the NNEBFPG frame or the NNFEBFPG frame assembly to the wall. Ensure that the NN(F)EBFPG frame remains centered on the dummy unit frame. **Refer to page 13.**

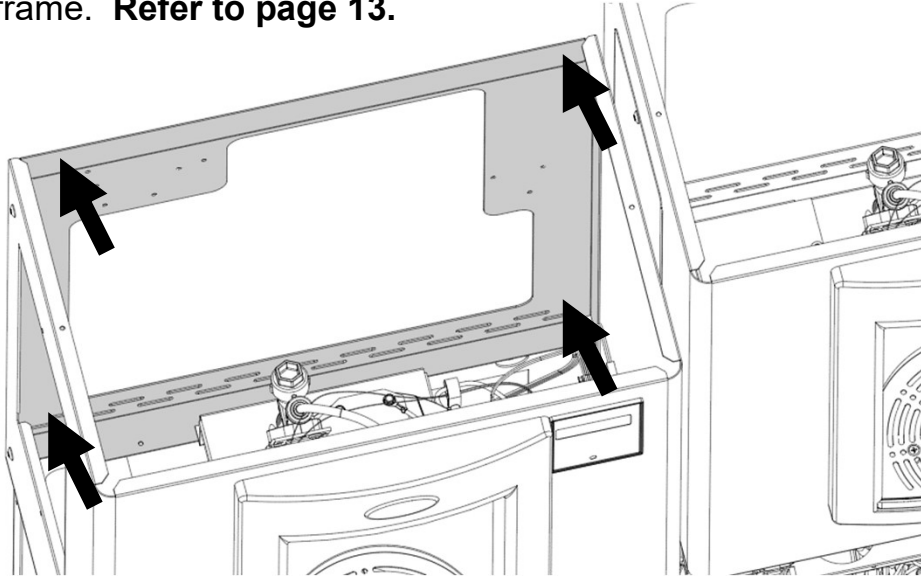

12. Install the Filter Guard Bracket. Refer to **page 13.**

13. Connect the two kits by re-installing the split level drainpipes to the NN(F)EBFPG drainpipes as shown below by connecting them to the drainpipes and fittings provided. Cut the provided drainpipes as needed.

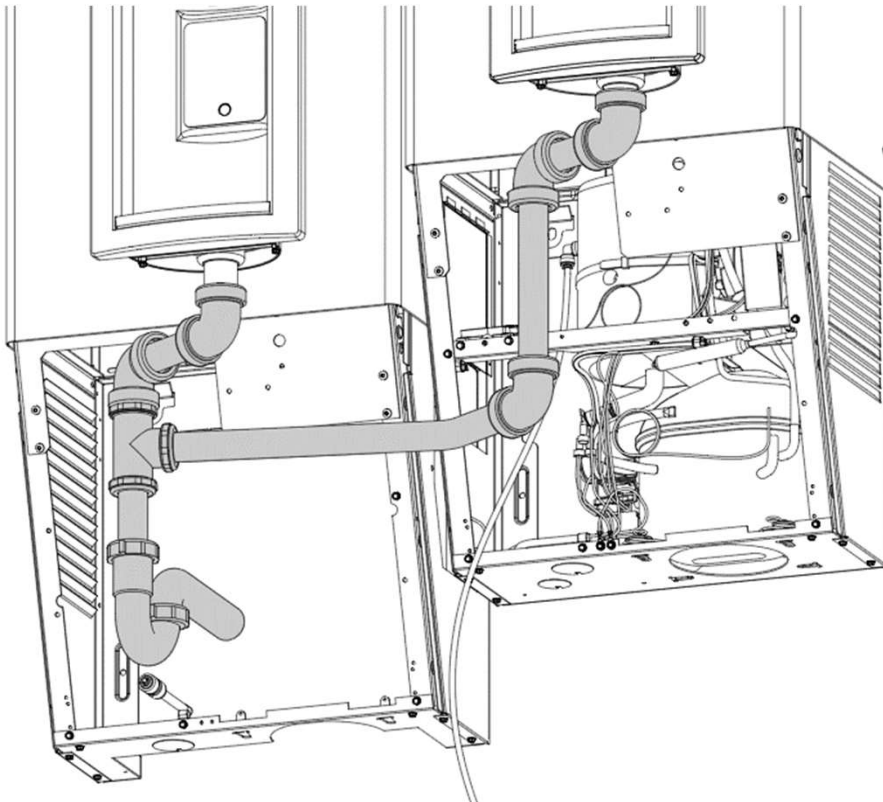

## Section 6: Split Level Installation

14. Model NNEBFPG, reconnect the water source line to the water inlet but **DO NOT** turn on the water.
15. Model NNFEBFPG with Versafilter III, remove the water source line to the water inlet. See Section 4: Step 8 for connecting Filter Head Water Inlet & Outlet Lines, installing the Filter Cartridge on the Filter Head and Flushing the Filter.
16. Only one of the power cords from the two NN(F)EBFPG kits will be used. Install the strain relieving p-clip roughly 36" from the three-prong wall plug. Secure the p-clip to the frame using the #8 hex tapping screw provided. **DO NOT plug in the unit.**

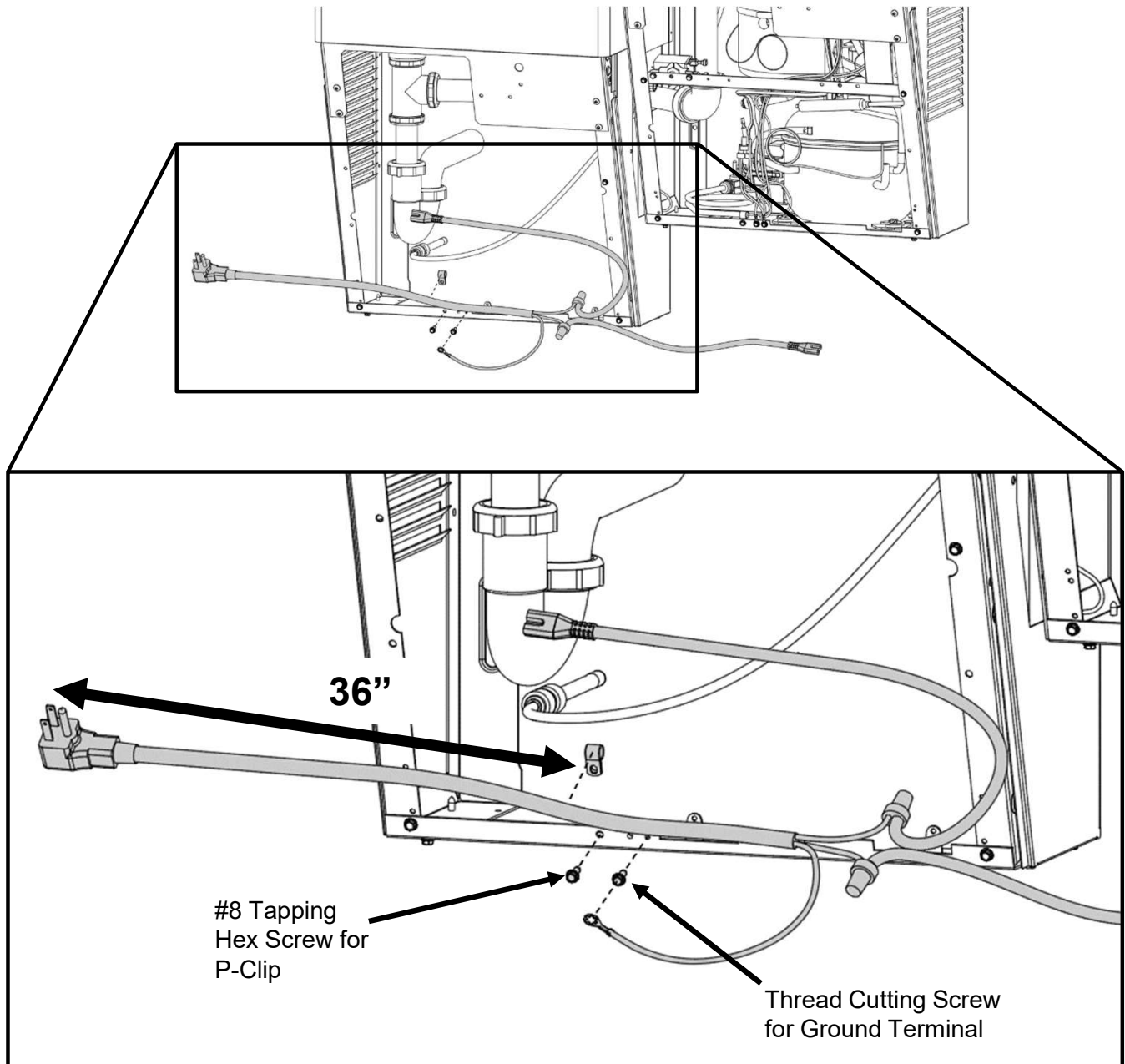

## Section 6: Split Level Installation

17. Connect each of the power bricks in each NN(F)EBFPG kit with one of each of the two IEC connectors. Ensure that the wires will not obstruct the fan blade.

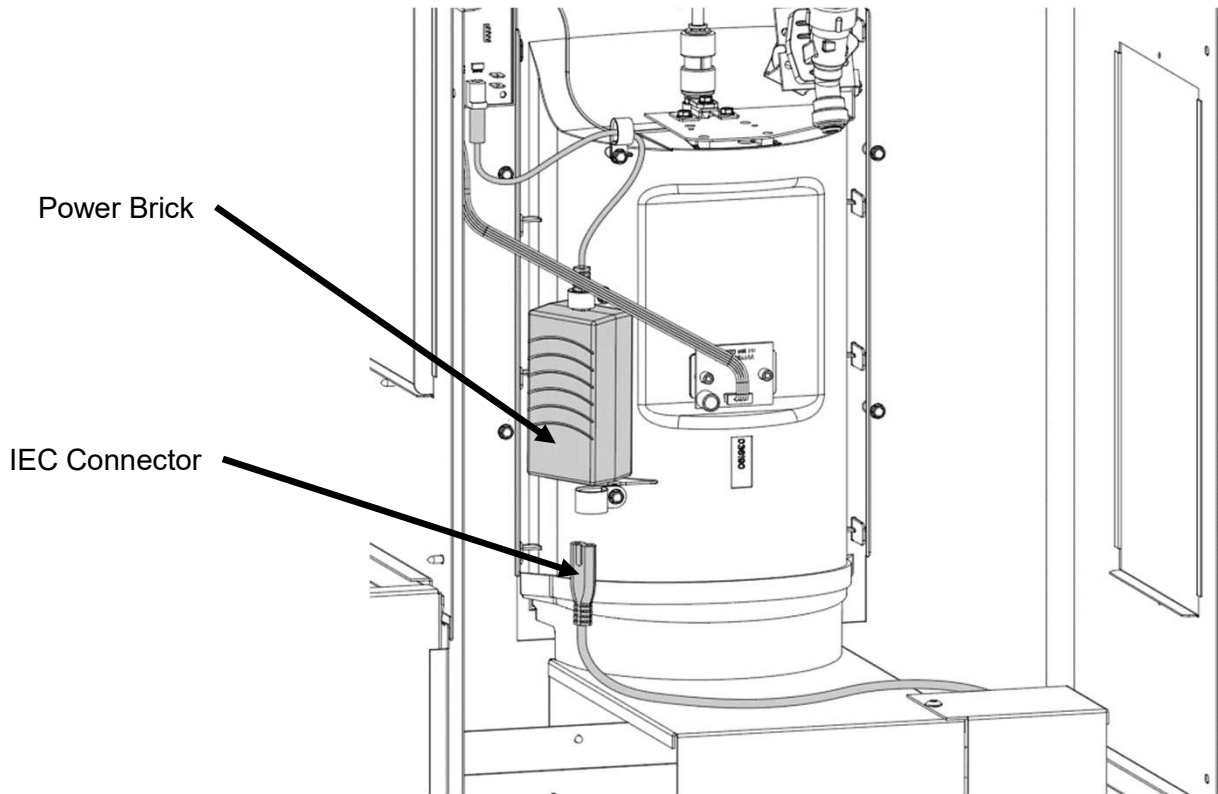

18. Connect the provided insulated 10" water tubing to the cooling tank water out line with the union fitting provided. Refer to **page 19**.
19. Turn on the water to the units and check for leaks.
20. Plug in both power cords into the duplex outlet and check for proper functions.
21. Install the fountain front panels (refer to **page 20**). Next, install the NN(F)EBFPG top and filter access panels (if removed) to complete the retrofit kit installation.

# Section 7: Set-Up Guide For OASIS® Hands-Free Bottle Filler Electronics

## Factory default program settings are:

- Units - Gallons
- Unfiltered unit
- Flow Meter = Rate Selected
- Filter Capacity = 1250 gallons [4731 liters] for a VersaFilter
- Bottle Count = 0.5L (1 Bottle)
- Flow Rate = 1.2 GPM
- 20 second maximum dispense time

**For each model** top cap will need to be set aside until programming is complete. Remove top cap by unscrewing two (2) T15 torx screws if needed. Remove wire tie bundling pushbutton inside bottle filler and feed it through hole in cooler top. You can then adjust program using pushbutton through access panel of cooler.

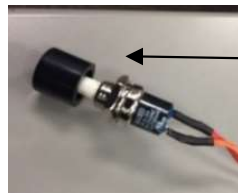

Pushbutton

## To change the program settings, follow these steps:

<i>Display</i>	<i>Action</i>
00000000 BOTTLES REUSED (Home Screen)	Depress button for 3 seconds to enter into the following menu settings and make changes. Note: at anytime it will exit menu and save settings when idle for 10 seconds (no button press) and revert back to Home Screen.
LTR/GAL GAL	Depress button 3 seconds to change from Gallons to Liters, or momentary press to advance to next menu.
UNFILT/FILT? UNFILT UNIT	Depress button 3 seconds to change from Unfiltered to Filtered unit, or momentary press to advance to next menu.
FLOW METER? RATE SELECTED	Depress button 3 seconds to change from Rate Selected to (Flow) Meter Enabled, or momentary press to advance to next menu.
SELECT RATE 1.2 GPM UNIT	To change flow rate, momentarily depress button to change whole gallon digit. Hold button 3 seconds to advance to TENTHS of gallon digit. Depress momentarily to change the digit. Hold button 3 seconds to advance to the next menu.
RESET 00000000 GALLON CNT [LTR COUNT]	Depress button for 3 seconds to reset Gallon or Liter count, or momentary press to advance to next menu.
FILT CAPAC OF 1250 GAL [4731 LTR]	Depress button for 3 seconds to change filter capacity to 3000 GAL [11355 liters] for Galaxi green filter, or Repeat this step to program for 4750 [18050 liters] gallons for Versafilter III or momentary press to advance to next menu.
3 sec rule? 0.5L	Depress button for 3 seconds to switch from 0.5L bottle to 3 sec rule, or momentary press to advance to next menu. (The 3 Sec rule increases the bottle count based on a 3 second dispense.)
Reset 00000000 BOT COUNT?	Depress button for 3 seconds to reset (Home Screen) BOTTLES REUSED count, or momentary press to advance to next menu.
Bot Filler Set_time: 20 s	Depress button for 3 seconds to change maximum dispense time to 10, 20 or 30 seconds, or momentary press to advance to next menu.
RUN CAL AGAIN?	Depress button 3 seconds to run calibration again, or momentary press to advance to next menu.

# Section 8: Parts Breakdown

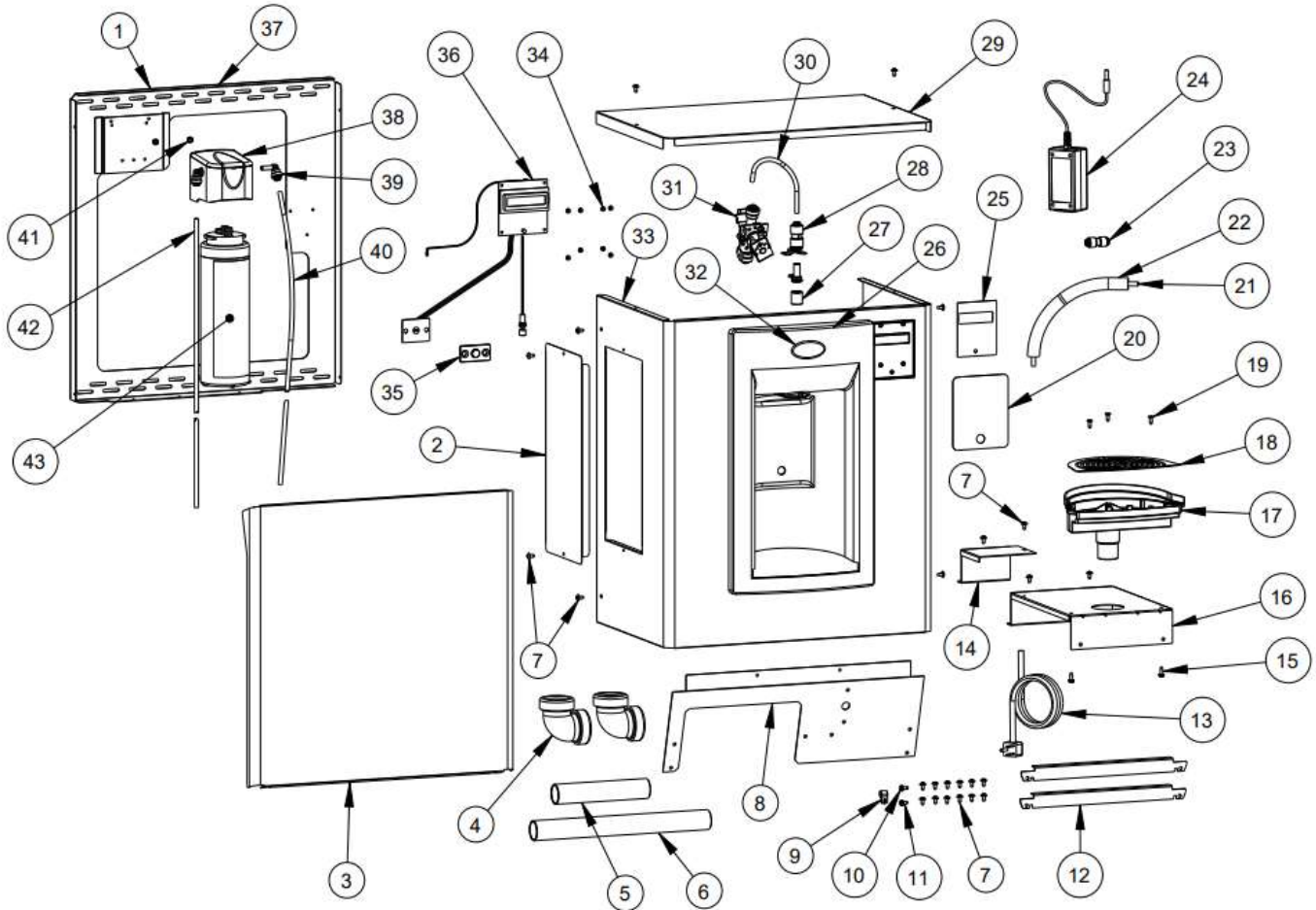

ITEM	QTY	P/N	Description
1	1	036687-003	FRAME
2	1	041241-001	Panel, Filter
3	1	041250-001	Panel, Front
4	2	A020967	1-1/2" Elbow, W/Nuts, 1-1/4"
5	1	036010-002	Waste Tube 6.13"
6	1	036010-013	Waste Tube 16.63"
7	24	031875-003	Screw, Truss HD Tapping Torx #8
8	1	041243-002	Bracket, Center
9	1	018541	Clamp, Strain Relief
10	1	026670-001	Screw, Hex HD Machine #8 x 3/8"
11	1	026642-003	Screw, Hex HD Tapping #8 x 3/8"
12	2	041242-002	Bracket, Side
13	1	041207-001-SP	Power Cord Assembly
14	1	041246-002	Bracket, Filter Support
15	1	026642-006	Screw, Hex HD Tapping #8 x 1/2"
16	1	041244-002	Bracket, Drip tray
17	1	036191-001	Drain
18	1	036192-001	Grille, Stainless

ITEM	QTY	P/N	Description
19	3	026675-003	Screw, Flat HD Tapping #8 x 1/2"
20	1	038031-006	Label, Alcove Sensor
21	1	030152-102-SP	Tube, PE 10" Long
22	1	017681-003-SP	Insulation, Sponge Tube 9"
23	1	028605-101	Fitting, PP Union 1/4"OD
24	1	038036-003	Power Supply, 100-240VAC/12VDC
25	1	038031-005	Label, LCD Bezel
26	1	036190-003	Alcove
27	1	038032-001	Flow Nozzle Assembly
28	1	028668-101	Fitting, PP Reducing Union
29	1	041239-002	Panel, Top
30	1	030152-033-SP	Tube, PE 6.5"
31	1	038030-002	Solenoid Valve 12VDC
32	1	031434-014	Nameplate, Oasis
33	1	041238-002	Wrapper
34	8	026824-026	Nut, Hex Nylon #4
35	1	038037-001	Lens, IR Bottle Filler
36	1	038026-002	Electronics Assembly, IR/LCD

For NNFEFBPG Only			
37	1	041410-001	Filter Bracket Frame Assembly
38	1	041146-001	Head Assy, Manifold w/Elbow Ftg.
39	1	029994-103	Fitting, PP Elbow Plug-in 1/4"OD
40	1	030152-046-SP	Tube, PE 38" Long
41	2	026642-003	Screw, Hex HD Tapping #8 x 3/8"
42	1	030152-046-SP	Tube, PE 38" Long
43	1	041145-001	Filter Cartridge, Versafilter III



**OWNER'S COPY**

**1 YEAR**

**BOTTLE FILLER LIMITED WARRANTY**

**FIRST YEAR**

The manufacturer promises the original purchaser (user) to repair, give credit for, or, at the manufacturer's option, to replace any part of this bottle filler which proves to be inoperative due to a defect in material or workmanship under normal use, for a period of one year from the date of original installation or for a period of eighteen (18) months after date of shipment from the factory, whichever occurs first. During the one year warranty, the Manufacturer will either replace, give credit for, or repair the bottle filler through its approved service center or factory repair department, and provide labor and parts necessary to correct such inoperative condition at no charge, if it has been installed and operated in accordance with the written instruction furnished with the bottle filler.

If it becomes necessary to ship the inoperative bottle filler to the approved service center or factory repair department, the Manufacturer will pay the transportation charges both ways via common carrier. Local delivery charges are not covered.

The cost of labor required to disconnect and reconnect plumbing and electrical connections will be the responsibility of the user (owner).

**WARNING**

Alteration or modification of this machine may cause serious flooding and/or hazardous electrical shock or fire.

Except as set forth herein, the Manufacturer makes no other warranty, guarantee or agreement expressed, implied or statutory, including any implied warranty of merchantability or fitness for a particular purpose.

The foregoing is in lieu of all other agreements expressed, implied or statutory and all other obligations or liabilities of the Manufacturer. The Manufacturer does not assume or authorize any person to assume any obligations of liability in connection with this product. In no event will the Manufacturer be liable for special or consequential damages or for any delay in the performance of this agreement due to causes beyond their control.

**GENERAL PROVISIONS AND EXCLUSIONS:**

This warranty applies only within the Continental Limits of the United States of America and Canada.

This warranty does not apply and no agreement, either expressed or implied, shall be applicable if the affixed serial number is removed, defaced or obliterated.

This warranty does not apply to any water components that become inoperative due to liming conditions.

This warranty does not apply to any bottle filler or components that become inoperable because of a failure to satisfy standards or regulations adopted by any government or agency thereof subsequent to the date of shipment from the factory.

This warranty does not cover performance, failure or damages of any parts resulting from external causes such as alterations, abuse, misuse, misapplication, corrosion or acts of God.

This warranty applies only to the bottle filler portion. It does not apply to the water cooler. Refer to the water cooler warranty for coverage.



OASIS International  
222 East Campus View BLVD • Columbus, OH 43235 U.S.A.

Phone: 1-800-950-3226  
Email: [www.oasiscoolers.com](http://www.oasiscoolers.com)

**THIS PAGE IS INTENTIONALLY LEFT BLANK**

# Model NNEBFPG and NNFEBFPG Chilled Bottle Filler Retrofit Kit for OASIS P8AC Water Coolers

## Installation Instructions

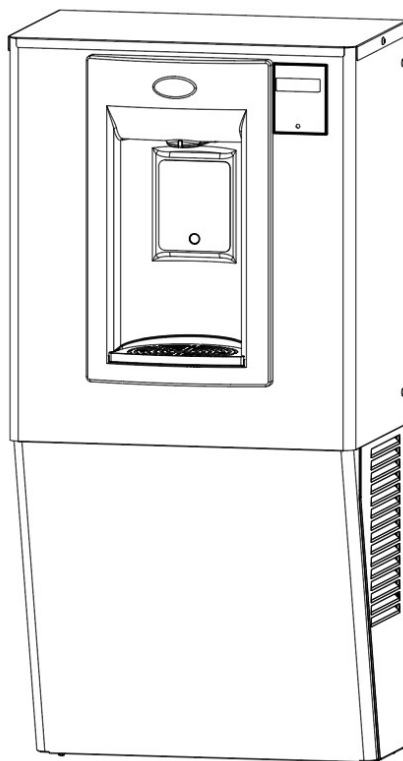

P/N 030099-658 Rev B Date: 05/2022

© 2022 LVD Acquisition, LLC

Oasis, Aqua Pointe, Versacooler and VersaFiller are registered trademarks of LVD Acquisition, LLC dba Oasis International



OASIS INTERNATIONAL  
222 East Campus View Blvd.  
Columbus, OH 43235  
614-861-1350  
[www.oasiscoolers.com](http://www.oasiscoolers.com)