

MODULAR SPORTS BOTTLE FILLER
OASIS® MWSBF, MW8SBF, MW12SBF, M8SBF, M12SBF
INSTRUCTIONS

1. INSPECTION

Inspect the cartons and various components for evidence of rough handling and concealed damage. Damage claims should be filed with the carrier.

2. INSTALLATION, PLUMBING & ELECTRICAL CONNECTIONS

- a) **Note:** The following states require a licensed plumber to install cooler; AR, GA, MA, MI, OK, RI, SC, SD, TX, VT and WI. CA, KS, MN, NM and OR allow for a state-registered installer or contractor as well. State and local plumbing codes may prohibit the use of saddle tapping valves for water line connection in some applications. All connections must conform to applicable plumbing codes.
- b) Plumbing rough-in and wall opening should be prepared as shown on roughing-in drawing.
- c) Insert frame assembly into wall opening and secure to studs. **NOTE: FRONT FLANGE OF FRAME(S) MUST BE FLUSH WITH THE FINISHED WALL SURFACE.**
- d) Install drain receptor to frame with screws provided.
- e) A 2X4 junction box is provided for the installation of a 115 volt receptacle. The bottle filler is provided with a power cord with a grounded NEMA 15 plug. It is recommended that flexible conduit be used to supply power to the junction box and chiller if used. Check the electric current available. Type and voltage must be the same as listed on the unit data plate.
- f) Refer to the appropriate connection diagram for water and drain connections. Check for leaks.
- g) The lower panel can be secured with the provided key locks or screws. The M8SBF features one lockable and one non lockable lower panel, these are interchangeable.

MODELS WITH CHILLER

- h) Attach cradle mounting angles to unit mounting cradle with 4 screws provided. Slide unit mounting cradle into frame and secure in place with 4 screws, provided. (Cradle is used only when cooling unit is to be installed.) **NOTE: BOTTOM FLANGE ON CRADLE IS TO BE BEHIND FRAME FRONT FLANGE.**
- i) Slide cooling unit onto cradle.

M8SBF & M12SBF WITH FOUNTAIN

- j) Install the fountain mounting plate to the frame assembly using the provided screws.
 - k) Place the upper panel in place on the frame top angle and fasten with 2 screws, provided, at the bottom.
 - l) Remove the bottom plate from the fountain arm. Save the screws.
 - m) Snap the reveal gasket over the back end of the fountain arm.
 - n) Add compression connector, furnished by others, to the fountain waste tube and slide back approximately 3" out of the way. Refer to the appropriate connection diagram.
 - o) Hang the fountain on the mounting plate studs. **NOTE: AS THE FOUNTAIN IS HUNG, FEED THE WASTE TUBE INTO THE WASTE STUB ON THE WALL SIDE.**
 - p) Tighten the fountain to the mounting plate with the 5/16-18 nuts and washers and the 1/4-20 bolts and washers provided.
 - q) Slide the reveal gasket(s) back into the notch between the panel and the arm. The gasket serves as an appearance item only (to close up any opening around the panel and the mounting plate).
- 3. OVERLOAD PROTECTION** (systems with chiller)
The compressor motor is equipped with an automatic reset protector which will disconnect the motor from the line in case of overload.
- 4. LUBRICATION** (systems with chiller)
This unit is equipped with a hermetically sealed compressor. No additional lubrication is required. The fan motor installed on this unit seldom needs oiling. If required, a few drops of SAE 10 oil should be used.
- 5. TO DISCONTINUE USE OF SYSTEMS WITH CHILLER**
Drain cooler when removed from service: (1) Remove grille, (2) Close supply valve, (3) Provide container to catch water, and remove drain plug.
- 6. MAINTENANCE** (systems with chiller)
The only maintenance required is the removal of dirt and lint from the condenser. Inspection should be made at 3 month intervals. Remove the grille and clean the condenser with a vacuum attachment.

WARNING

The warranty and the Underwriters' Laboratory Listing for this machine are automatically voided if this machine is altered, modified, or combined with any other machine or device. Alteration or modification of this machine may cause serious flooding and/or hazardous electrical shock or fire.

EXCEPT AS SET FORTH HEREIN, THE MANUFACTURER MAKES NO OTHER WARRANTY, GUARANTEE OR AGREEMENT EXPRESSED, IMPLIED, OR STATUTORY, INCLUDING ANY IMPLIED WARRANTY OR MERCHANTABILITY OR FITNESS FOR A PARTICULAR PURPOSE.



222 East Campus View Blvd. • Columbus, OH 43235 U.S.A.
1-800-950-3226
www.oasiscoolers.com

MODULAR SPORTS BOTTLE FILLER MODELS
 OASIS® MWSBF, MW8SBF, MW12SBF

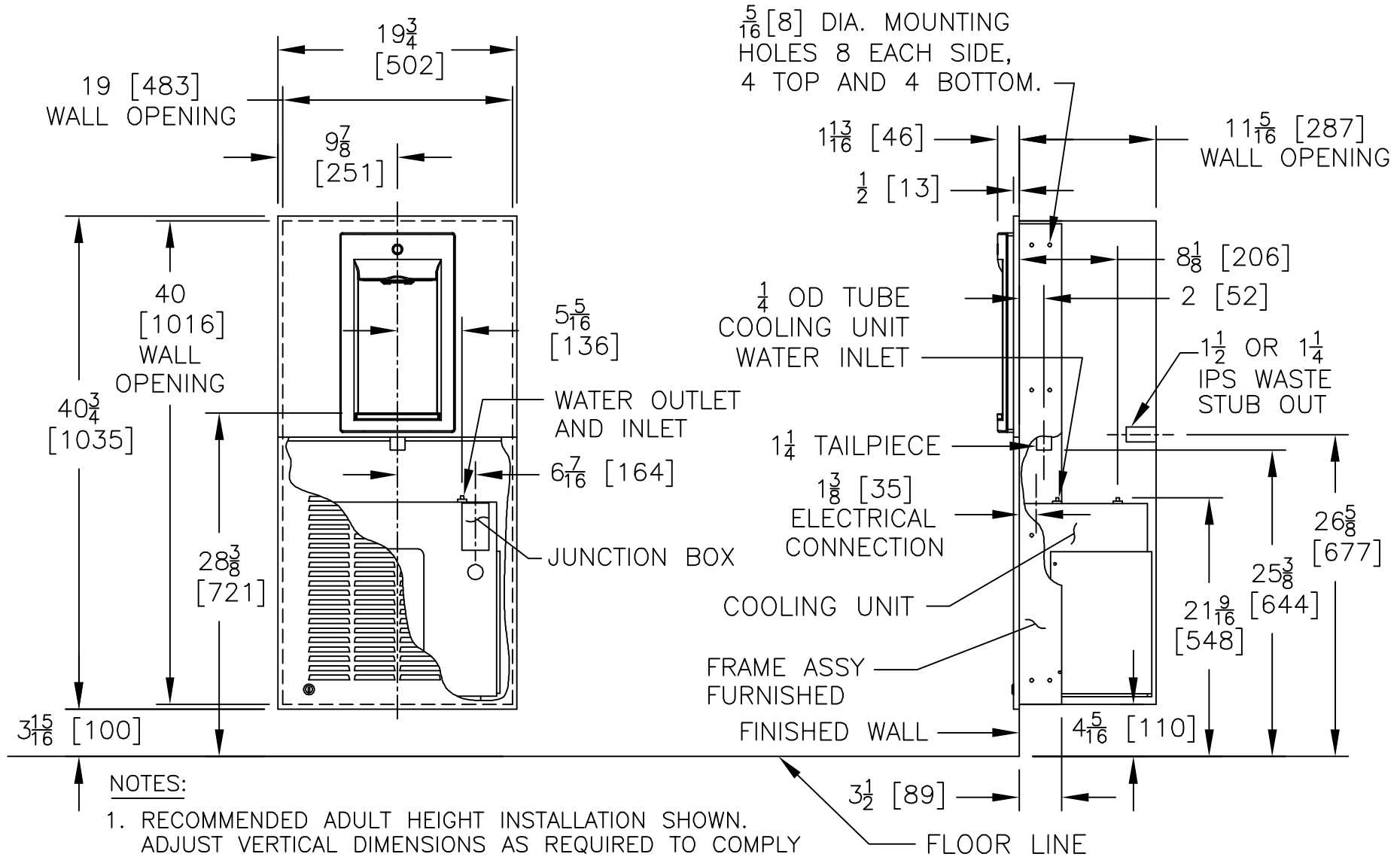

NOTES:

1. RECOMMENDED ADULT HEIGHT INSTALLATION SHOWN. ADJUST VERTICAL DIMENSIONS AS REQUIRED TO COMPLY WITH FEDERAL, STATE AND LOCAL CODES.
2. STOP VALVE, TRAP, PIPE CONNECTOR TO WASTE WASTE LINE NOT PROVIDED. SHORT RADIUS TRAP REQUIRED
3. ALL DIMENSIONS ARE IN INCHES. DIMENSIONS IN BRACKETS [] ARE IN MILLIMETERS.

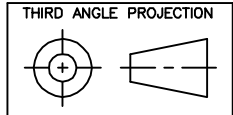

ROUGHING-IN AND DIMENSIONAL DRAWING

MODULAR SPORTS BOTTLE FILLER MODELS
OASIS® M8SBF, M12SBF

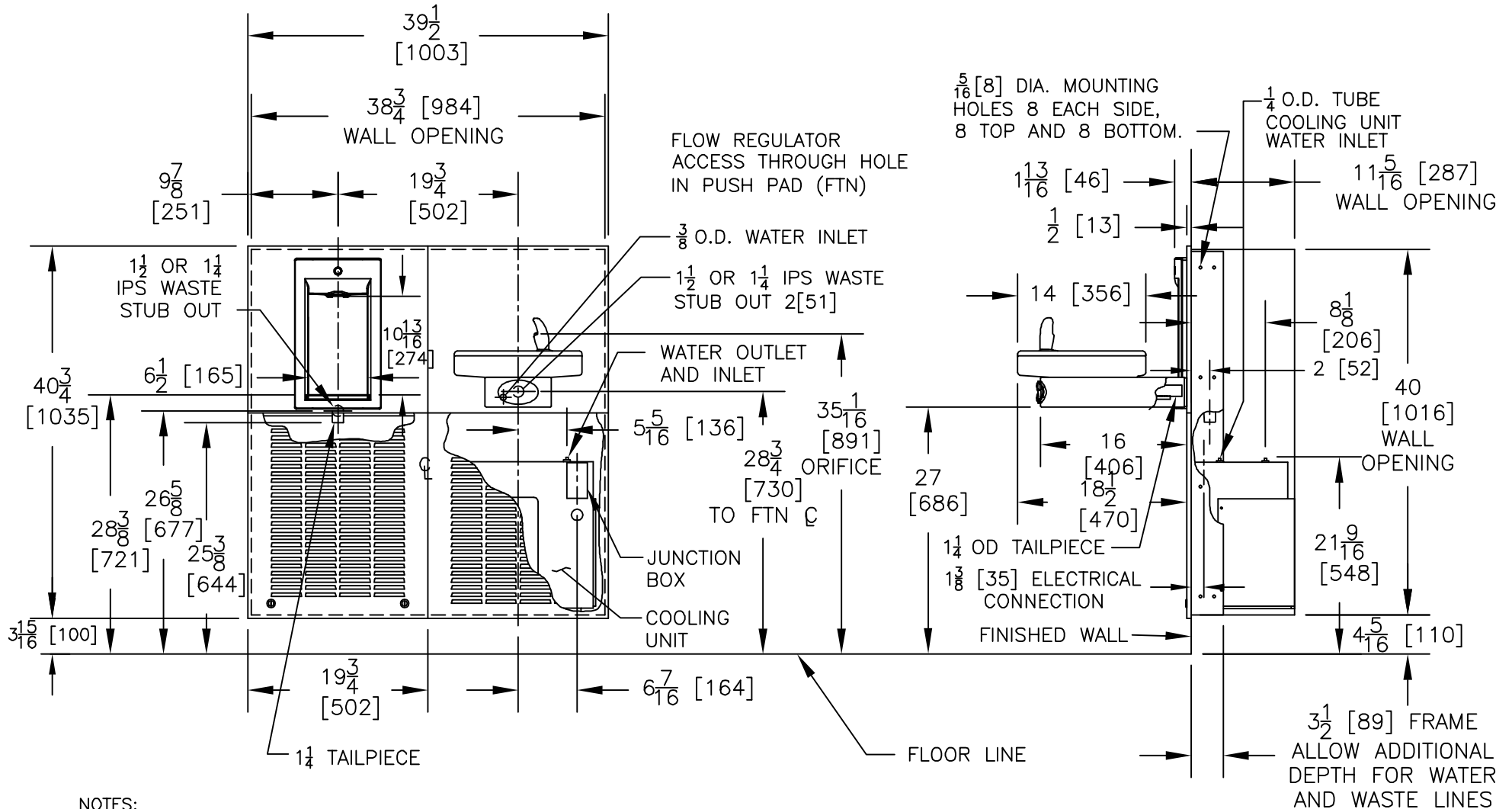

NOTES:

- RECOMMENDED ADULT HEIGHT INSTALLATION SHOWN. ADJUST VERTICAL DIMENSIONS AS REQUIRED TO COMPLY WITH FEDERAL, STATE AND LOCAL CODES.
- STOP VALVE, TRAP, PIPE CONNECTOR TO WASTE WASTE LINE NOT PROVIDED. SHORT RADIUS TRAP REQUIRED
- ALL DIMENSIONS ARE IN INCHES. DIMENSIONS IN BRACKETS [] ARE IN MILLIMETERS.

<p>THIRD ANGLE PROJECTION</p>	<p>ROUGHING-IN AND DIMENSIONAL DRAWING</p>
-------------------------------	--

Bottle Filler Assembly with Chiller

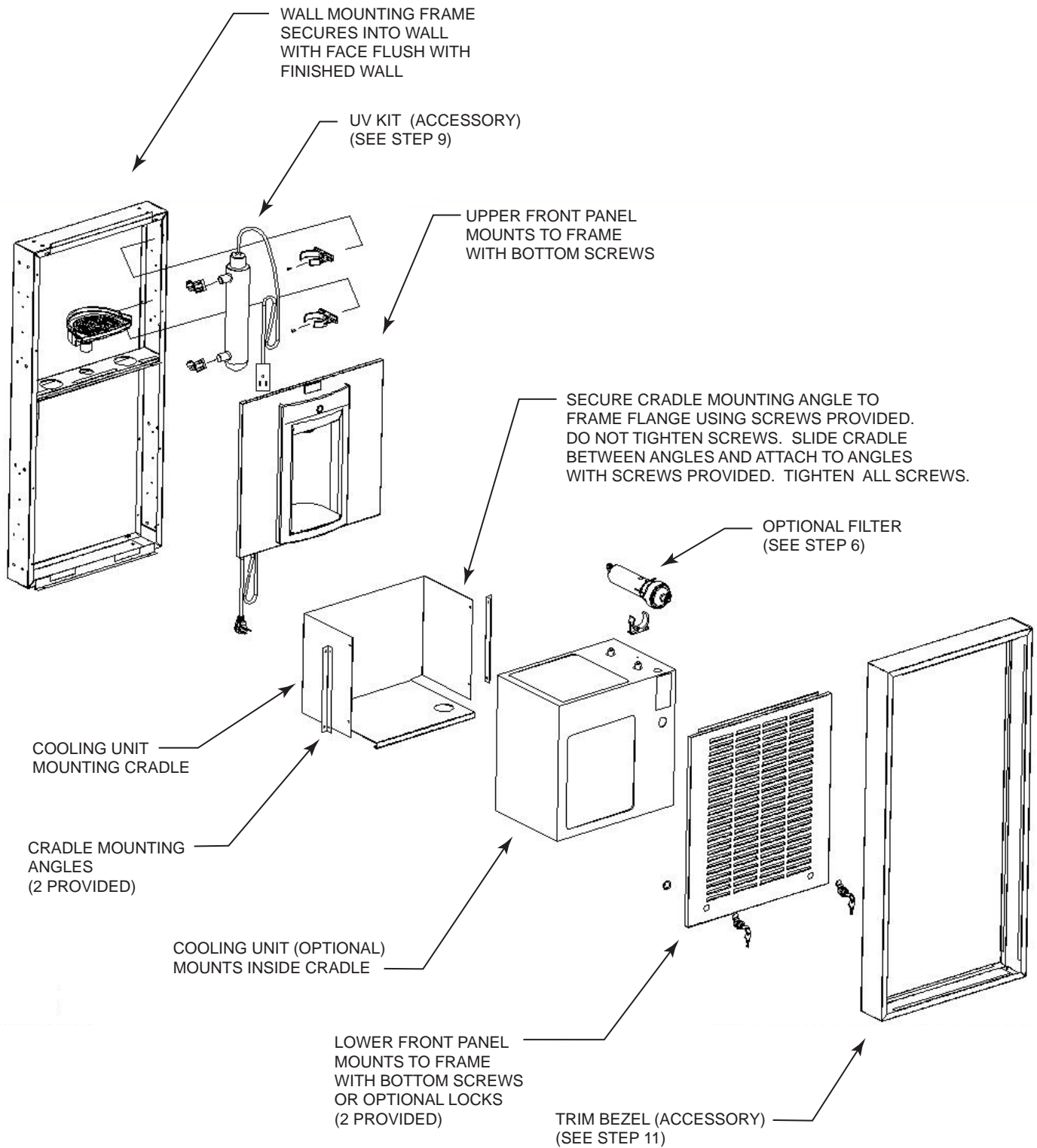

STEP 1

INSTALL MOUNTING FRAME

- Ⓐ INSTALL FRAME PER ROUGH IN DRAWING
- Ⓑ INSTALL DRAIN ASSEMBLY
- Ⓒ INSTALL SNAP BUSHINGS

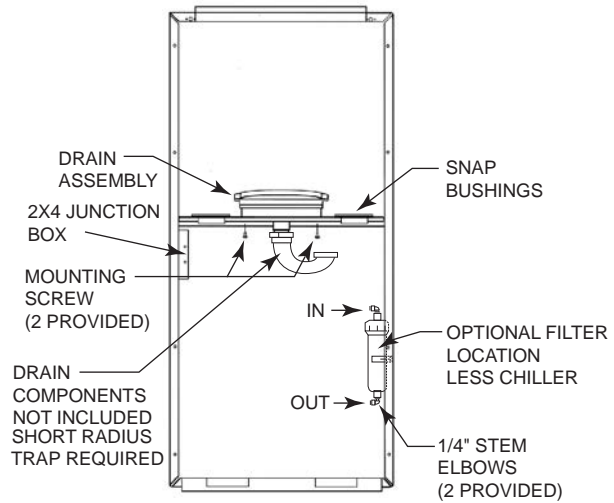

FIG. 1

STEP 2

MWSBF (WITHOUT CHILLER)

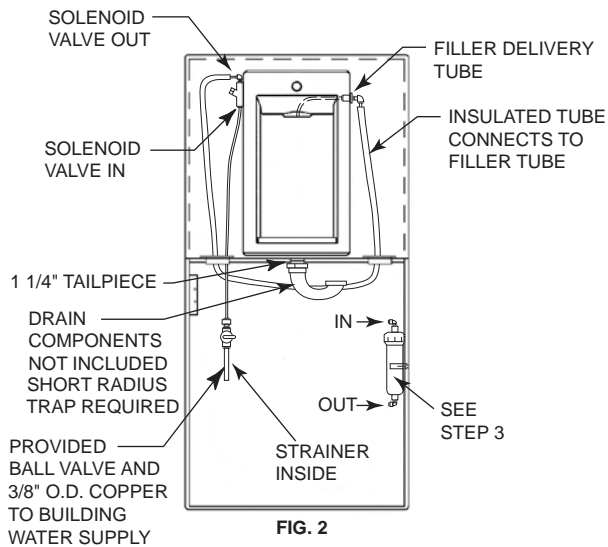

FIG. 2

- Ⓐ INSTALL PROVIDED BALL VALVE AND 3/8" O.D. COPPER TUBE TO BUILDING WATER SUPPLY
- Ⓑ INSTALL TUBING AS SHOWN BEFORE MOUNTING THE PANEL ASSEMBLY
- Ⓒ INSTALL UPPER PANEL ASSEMBLY (SCREWS PROVIDED)
- Ⓓ INSTALL LOWER LOUVER PANEL USING SUPPLIED LOCKS OR SCREWS

STEP 3

FILTER INSTALLATION (WITHOUT CHILLER)

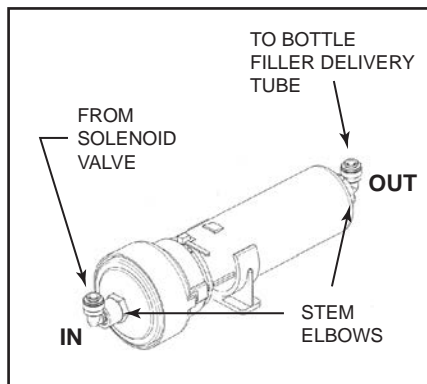

FIG. 3

- Ⓐ MOUNT FILTER CLIP TO FRAME (SEE FIG. 2)
- Ⓑ INSTALL PROVIDED STEM ELBOWS
- Ⓒ CUT WATER LINE FROM SOLENOID VALVE TO BOTTLE FILLER DELIVERY TUBE (SEE FIG. 2)
- Ⓓ CONNECT SOLENOID VALVE OUT TO FILTER IN
- Ⓔ CONNECT FILTER OUT TO FILLER DELIVERY TUBE

STEP 4

MW8SBF and MW12SBF (CONNECTING THE CHILLER)

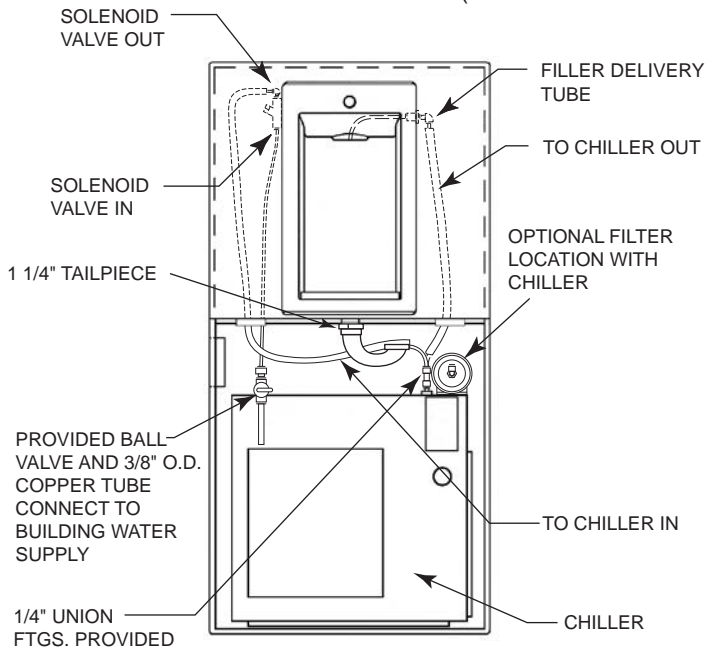

FIG. 4

- (A) ATTACH CRADLE TO FRAME PER ROUGH IN DRAWING. (SCREWS PROVIDED 4)
- (B) PLACE CHILLER IN FRAME
- (C) INSTALL 1/4" UNION FITTINGS ON CHILLER INLET AND OUTLET
- (D) RUN THE WATER LINE FROM THE BOTTLE FILLER SOLENOID VALVE "OUT" TO CHILLER "IN". CUT OFF EXCESS AND USE IT TO RUN FROM CHILLER "OUT" TO THE BOTTLE FILLER DELIVERY TUBE

STEP 5

FILTER LOCATION (WITHIN CHILLER)

- (A) SCREW FILTER CLIP TO UNIT IN LOCATION AS SHOWN IN FIG. 5 (SCREW PROVIDED)
- (B) INSTALL 1/4" STEM ELBOWS (PROVIDED) IN FILTER INLET AND OUTLET
- (C) PLACE FILTER IN CLIP AS SHOWN IN FIG. 6

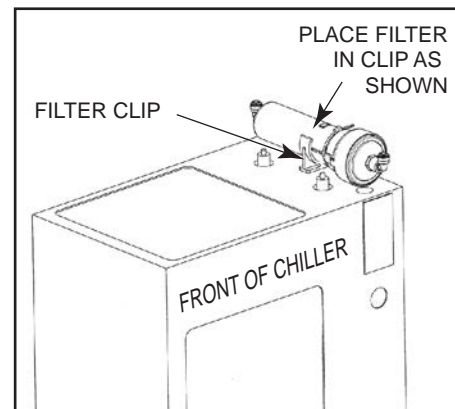

FIG 5

STEP 6

FILTER INSTALLATION (WITH CHILLER)

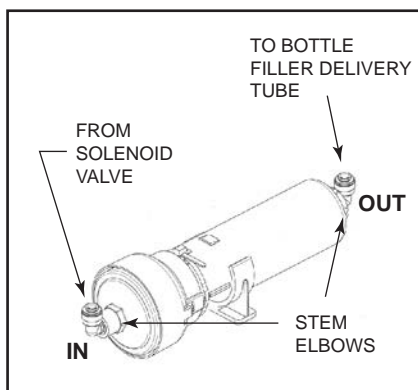
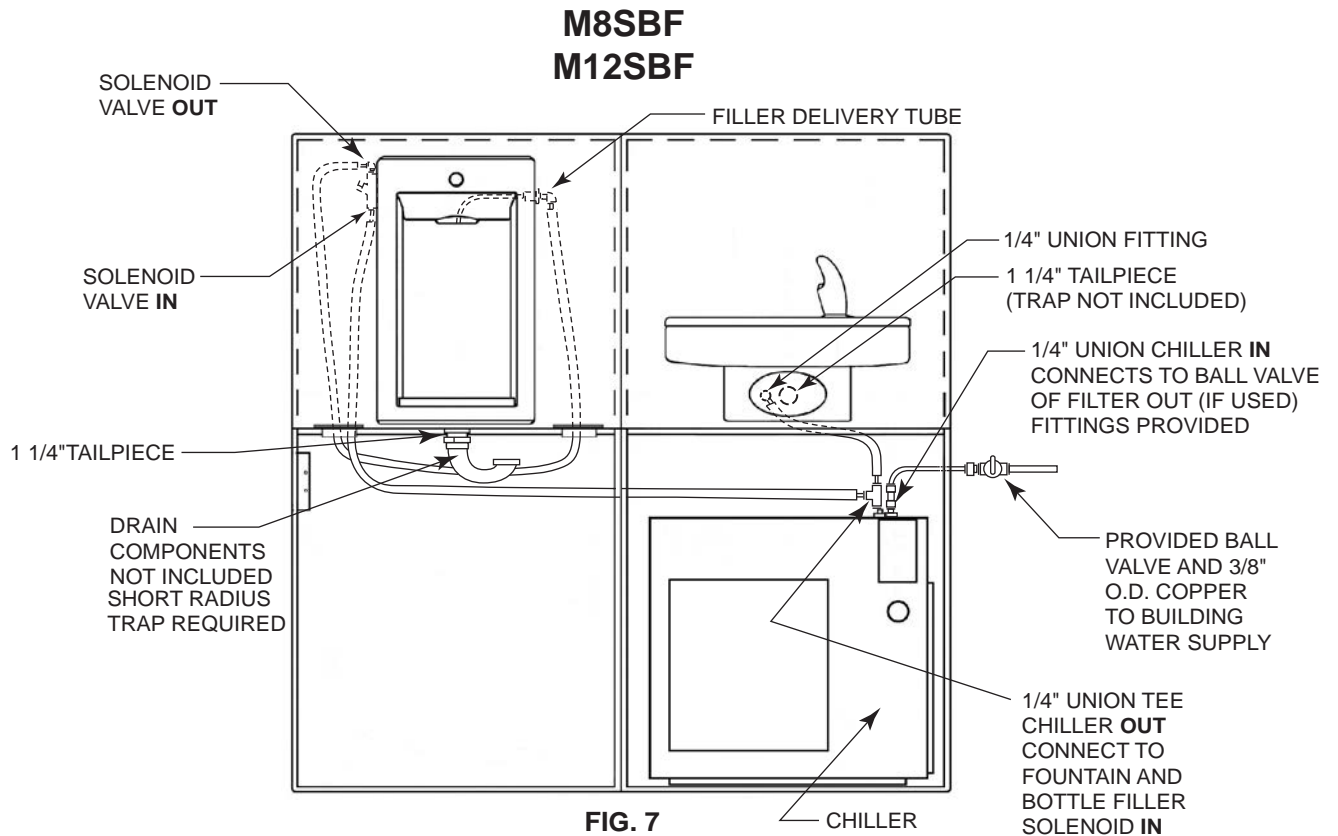

FIG 6

- (A) MOUNT FILTER TO CHILLER CASING (SEE FIG. 5)
- (B) INSTALL PROVIDED STEM ELBOWS
- (C) CUT THE WATER LINE FROM THE BOTTLE FILLER SOLENOID VALVE TO THE CHILLER INLET
- (D) CONNECT BOTTLE FILLER SOLENOID VALVE TO FILTER INLET
- (E) CONNECT FILTER OUT TO CHILLER INLET

STEP 7



CHILLER AND FOUNTAIN CONNECTIONS

- | | |
|---|--|
| <p>(A) INSTALL CHILLER IN FRAME</p> <p>(B) INSTALL 1/4" UNION ON CHILLER IN</p> <p>(C) CONNECT 1/4" UNION TEE TO CHILLER OUT</p> <p>(D) DETERMINE TUBE LENGTH NEEDED TO CONNECT BOTTLE FILLER SOLENOID IN (THE LINE WITH ATTACHED BALL VALVE) TO CHILLER TEE. CUT TUBE AND CONNECT</p> <p>(E) ATTACH REMAINING TUBE FROM BALL VALVE TO CHILLER IN</p> | <p>(F) REMOVE ADAPTER FITTING AND COPPER TUBE FROM FOUNTAIN WATER LINE. INSTALL PROVIDED 1/4" UNION</p> <p>(G) DETERMINE LENGTH OF TUBE NEEDED TO CONNECT BOTTLE FILLER SOLENOID OUT TO BOTTLE FILLER DELIVERY TUBE, CUT OFF EXCESS</p> <p>(H) USE EXCESS TUBE TO CONECT FOUNTAIN TO CHILLER TEE</p> |
|---|--|

STEP 8

FILTER CONNECTION (BOTTLE FILLER AND FOUNTAIN)

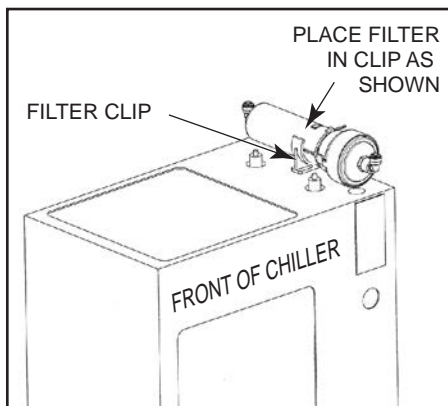

FIG 5

- (A) MOUNT FILTER TO CHILLER CASING (SEE FIG. 5)
- (B) INSTALL PROVIDED STEM ELBOWS (SEE FIG. 8)
- (C) CUT THE TUBE TO THE CHILLER INLET
- (D) CONNECT TUBING FROM BALL VALVE TO FILTER IN. CONNECT FILTER OUT TO CHILLER IN.

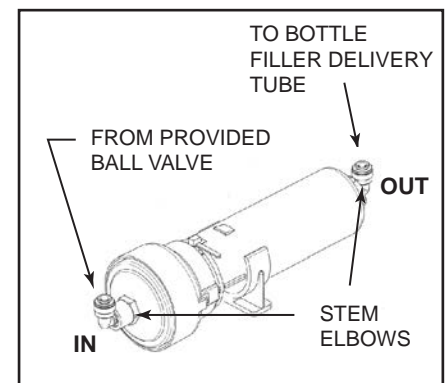

FIG. 8

UV KIT - INSTALLATION GUIDE

(BACK VIEW WITH CHILLER, UV, AND FILTER)

STEP 9

- (A) REMOVE LOWER AND UPPER FRONT PANELS, IF NEEDED
- (B) SCREW UV HOUSING CLIP TO FRAME (ONLY ONE CLIP REQUIRED). HOLES PROVIDED IN FRAME UPPER LEFT SIDE (BACK VIEW).
- (C) INSTALL INTER CONNECTING WATER FITTING TO UV HOUSING, PROVIDED. REFER TO FIG. 10 AND 11 FOR DETAILS.
- (D) INSTALL QUARTZ SLEEVE WITH O-RING INTO UV HOUSING. ASSEMBLE RETAINER NUT - DO NOT OVER TIGHTEN REFER TO FIG. 10 FOR DETAILS.
- (E) RUN UV POWER CORD CONNECTION THROUGH HOLE PROVIDED IN FRAME. CONNECT UV BULB TO POWER SUPPLY CORD AND INSERT BULB INTO UV HOUSING. SEE FIG.9 AND 10 FOR DETAILS.

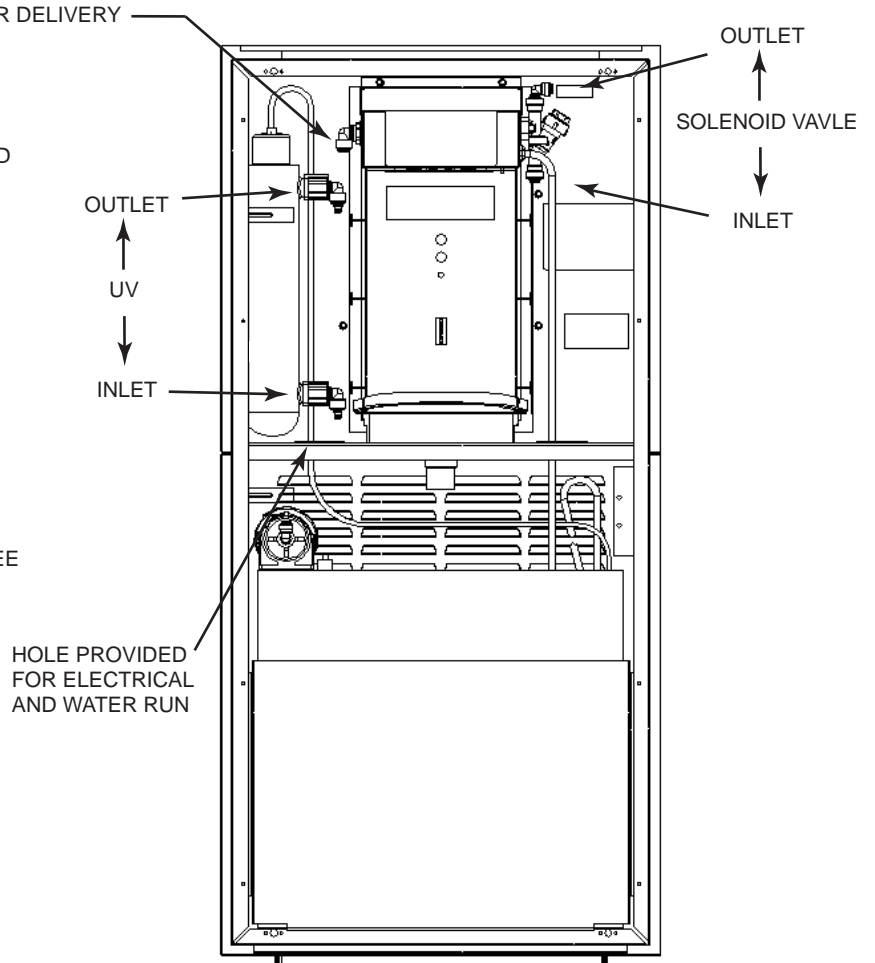

FIG. 9
(BACK VIEW)

STEP 10

- (A) CAUTION --- CAREFULLY SNAP UV HOUSING INTO CLIP INSTALLED IN STEP 9. THE UV BULB AND QUARTZ SLEEVE ARE MADE OF GLASS AND ARE FRAGILE. USE CAUTION IN THIS STEP TO AVOID DAMAGING THESE PARTS.
- (B) CONNECT ALL INTERCONNECTING WATER LINES. SEE WATER CIRCUIT ILLUSTRATION ON THE NEXT PAGE.
- (C) RE-CONNECT ELECTRICAL POWER AND INSTALL UPPER AND LOWER FRONT PANELS.

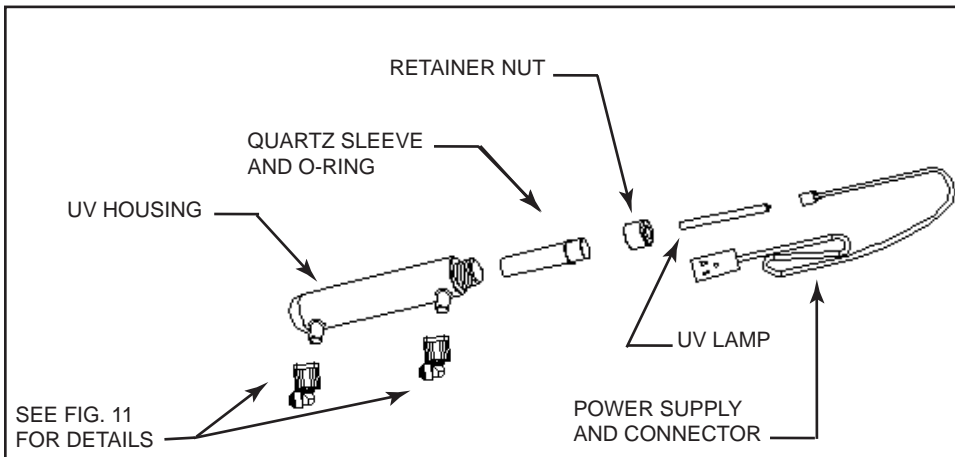

FIG. 10

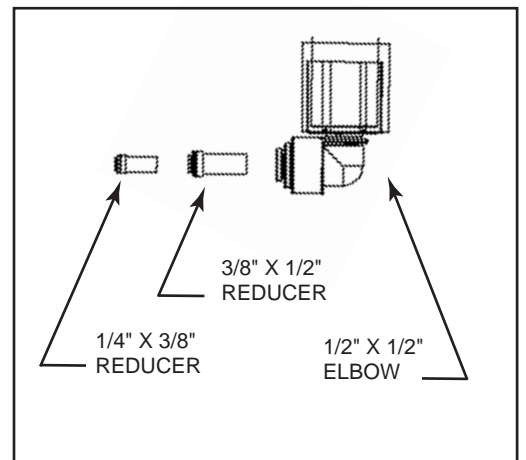
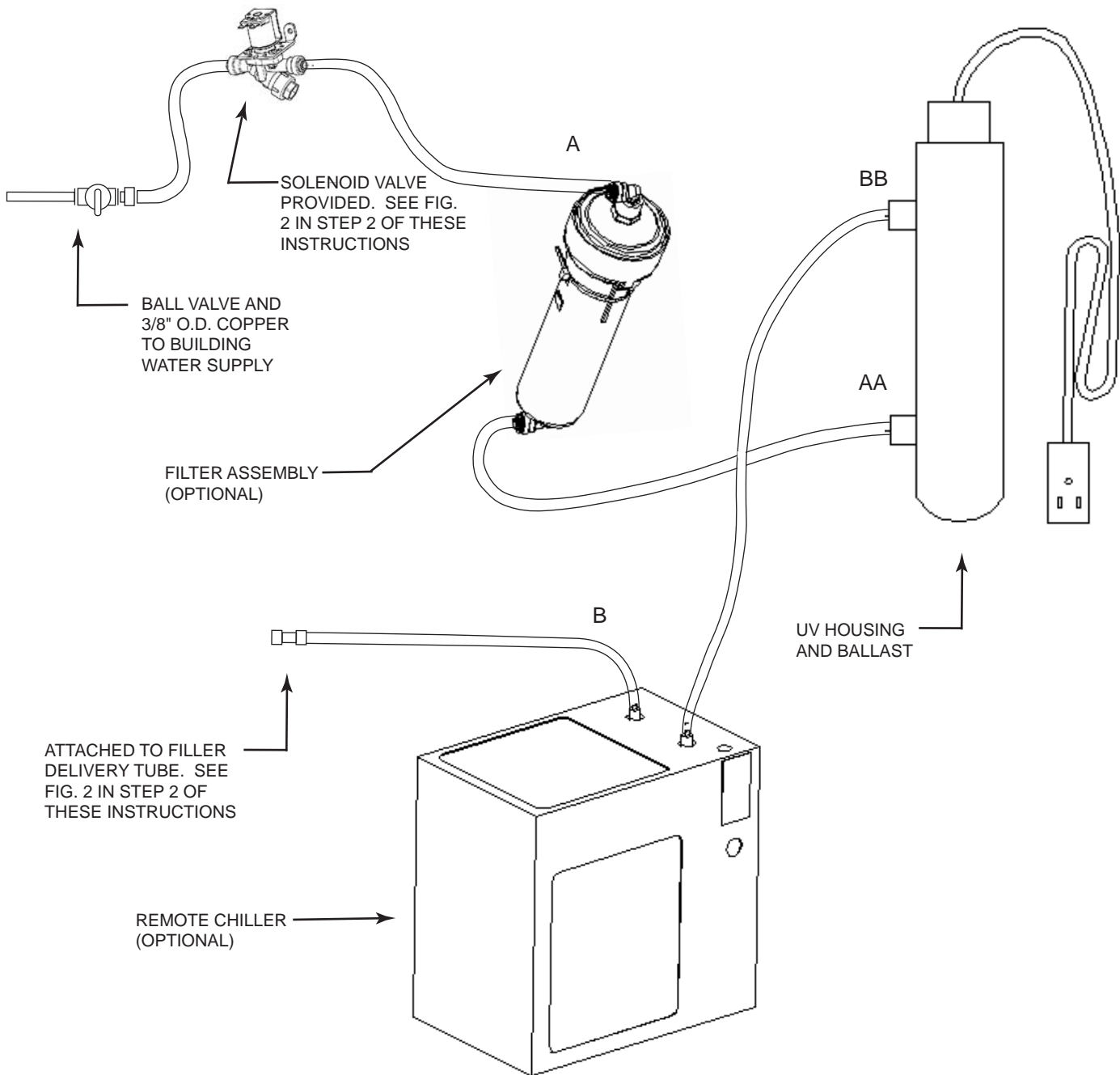

FIG. 11

UV KIT - WATER CIRCUIT



NOTE:

IF OPTIONAL FILTER ASSEMBLY IS NOT INSTALLED, CONNECTION "A" WILL CONNECT TO LOCATION "AA" OF THE UV ASSEMBLY.

IF OPTIONAL REMOTE CHILLER IS NOT INSTALLED, CONNECTION "B" WILL CONNECT TO LOCATION "BB" OF THE UV ASSEMBLY.

TRIM BEZEL INSTALLATION

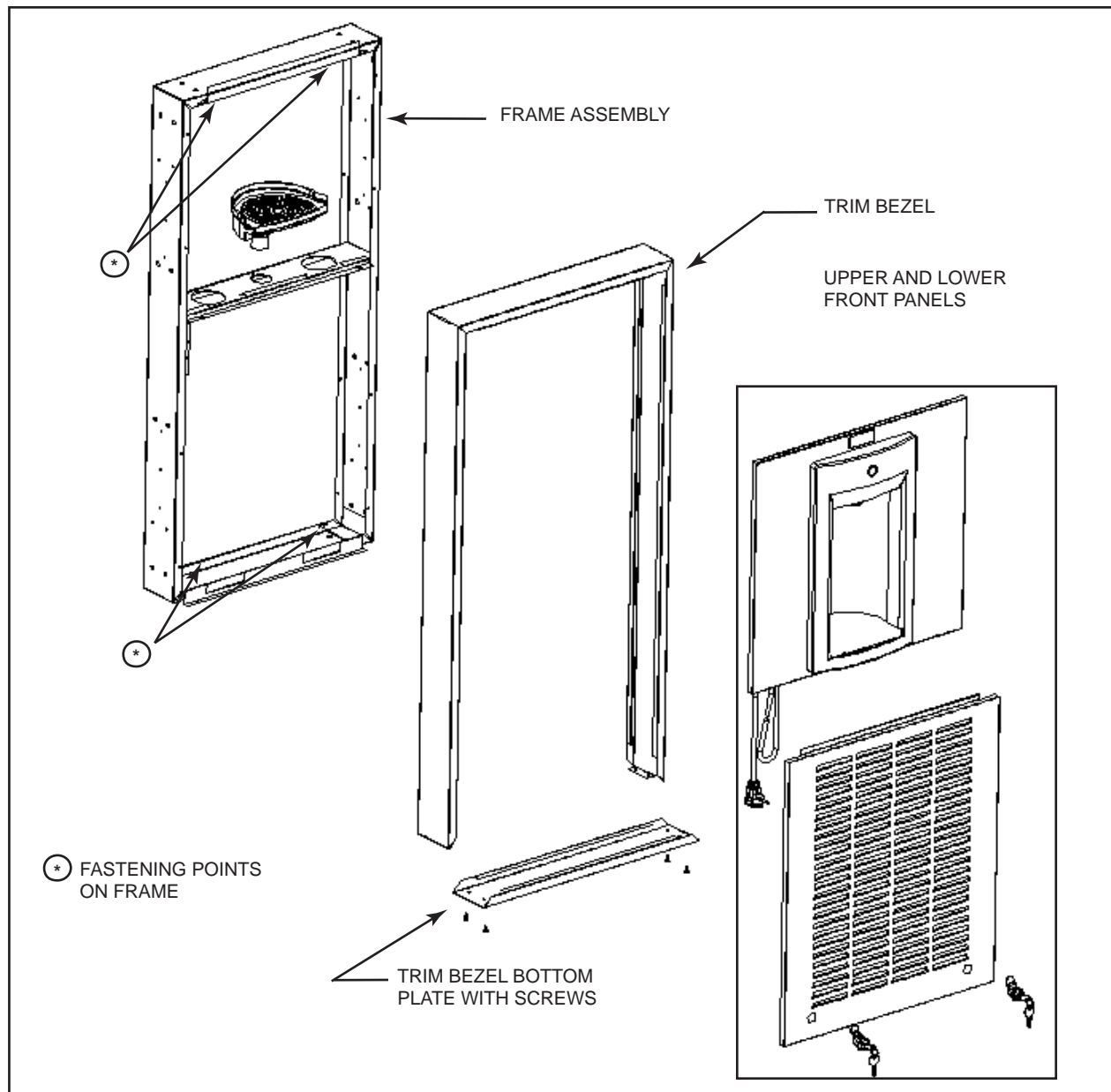
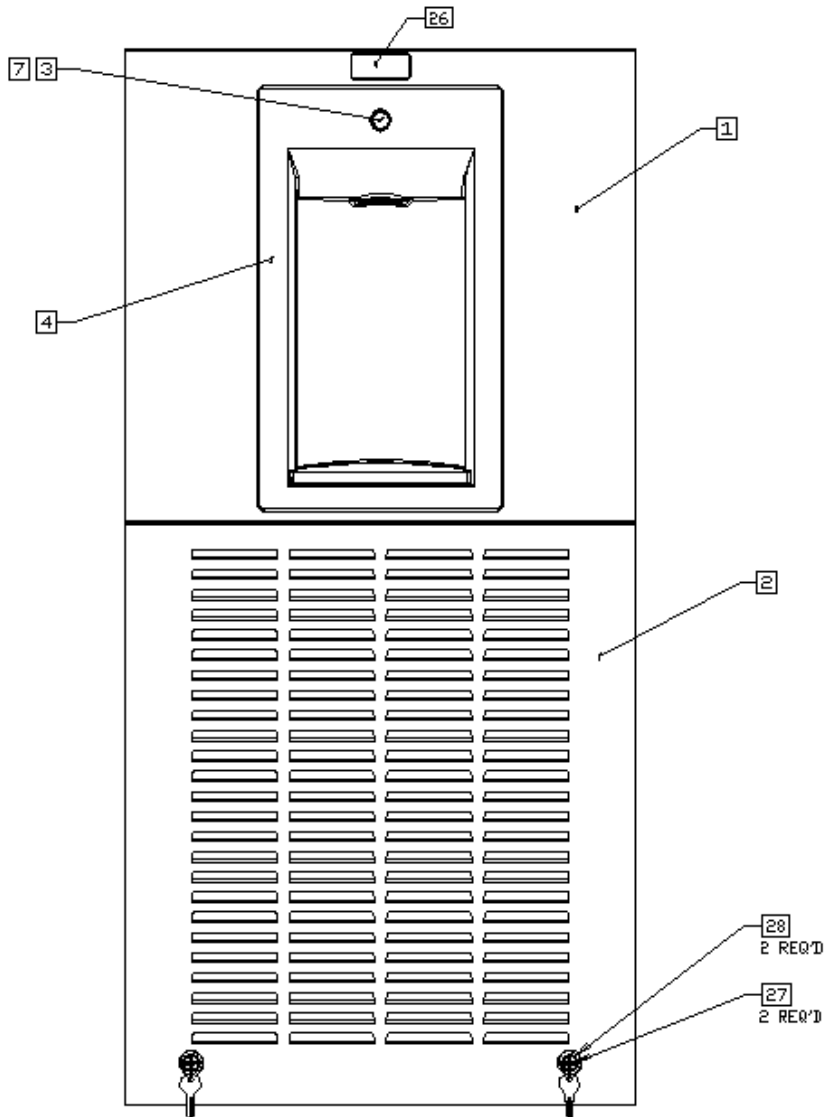
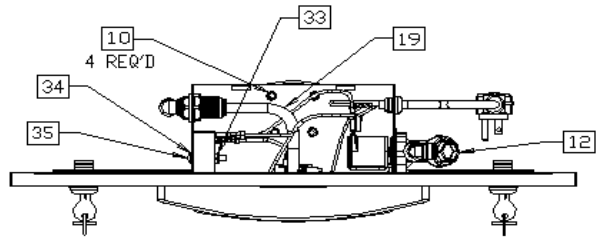
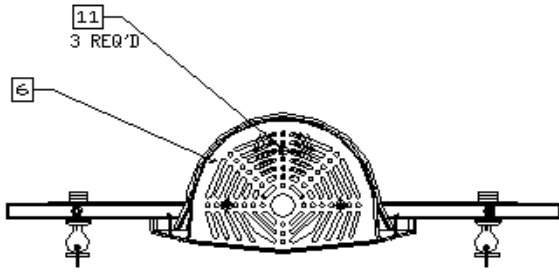

FIG. 11

STEP 11

- (A) INSTALL FRAME ASSEMBLY TO A FLAT SURFACE. USE APPROPRIATE FASTENING HARDWARE (NOT INCLUDED). REFER TO THE FIRST TWO PAGES OF THIS INSTRUCTION PACKAGE FOR CORRECT INSTALLATION HEIGHT.
- (B) REMOVE BOTTOM PLATE FROM TRIM BEZEL (4 SCREWS)
- (C) INSTALL TRIM BEZEL TO FRAME ASSEMBLY AND REPLACE BOTTOM PLATE WITH SCREWS.
- (D) INSTALL DRAIN ASSEMBLY, SNAP BUSHINGS AND ANY OTHER ACCESSORIES INCLUDED WITH THIS KIT.
- (E) INSTALL UPPER AND LOWER FRONT PANEL.

MODULAR SPORTS BOTTLE FILLER
OASIS® MWSBF, MW8SBF, MW12SBF, M8SBF, M12SBF
ILLUSTRATED PARTS BREAK DOWN



MODULAR SPORTS BOTTLE FILLER
OASIS® MWSBF, MW8SBF, MW12SBF, M8SBF, M12SBF
ILLUSTRATED PARTS BREAK DOWN

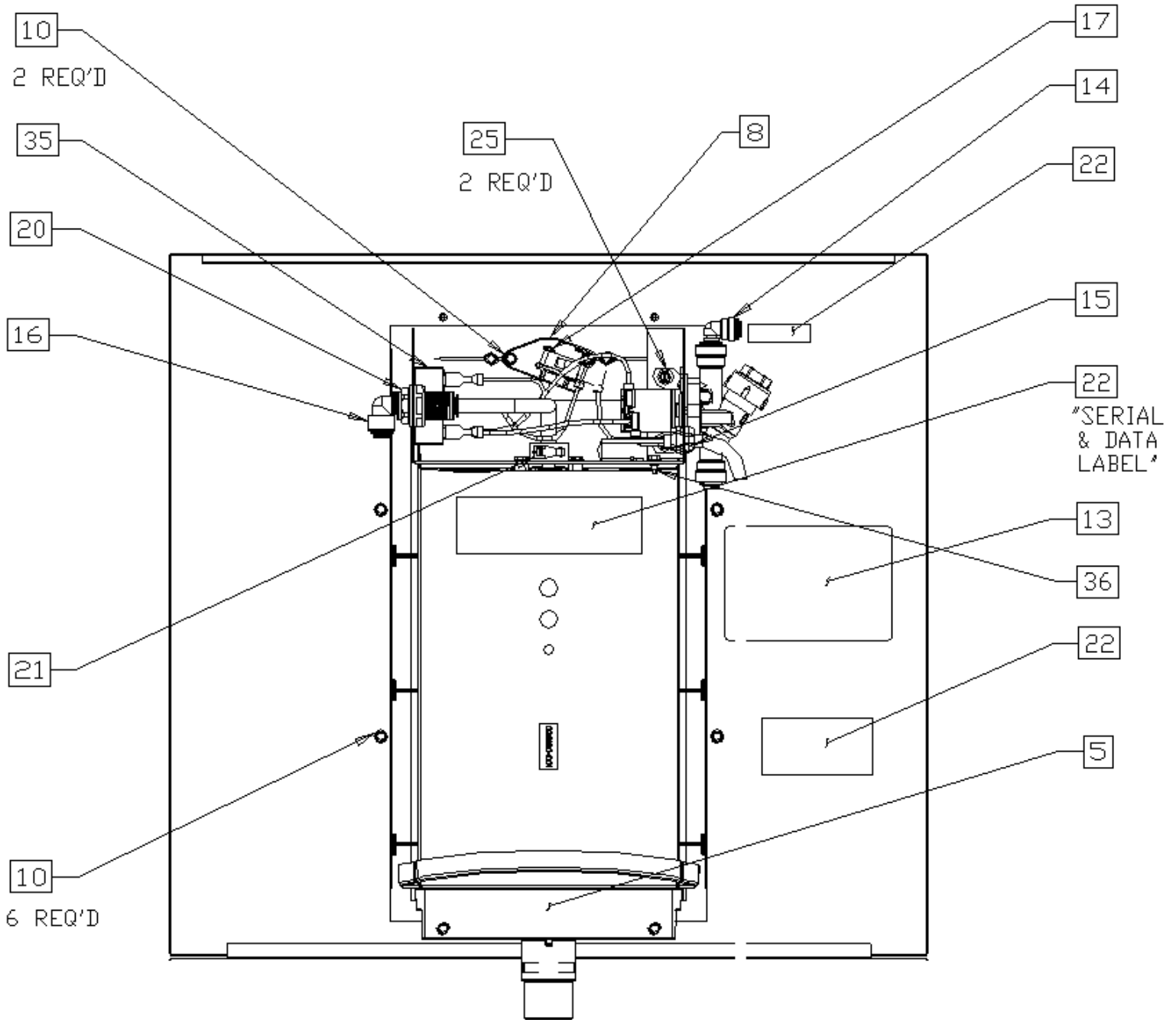

MODULAR SPORTS BOTTLE FILLER
OASIS® MWSBF, MW8SBF, MW12SBF, M8SBF, M12SBF
ILLUSTRATED PARTS BREAK DOWN

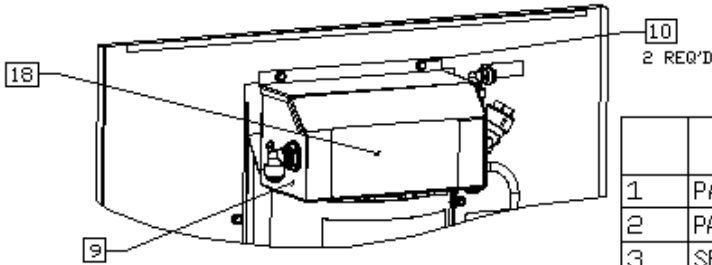

ITEMS NOT SHOWN: 23 24 29 30 31 37

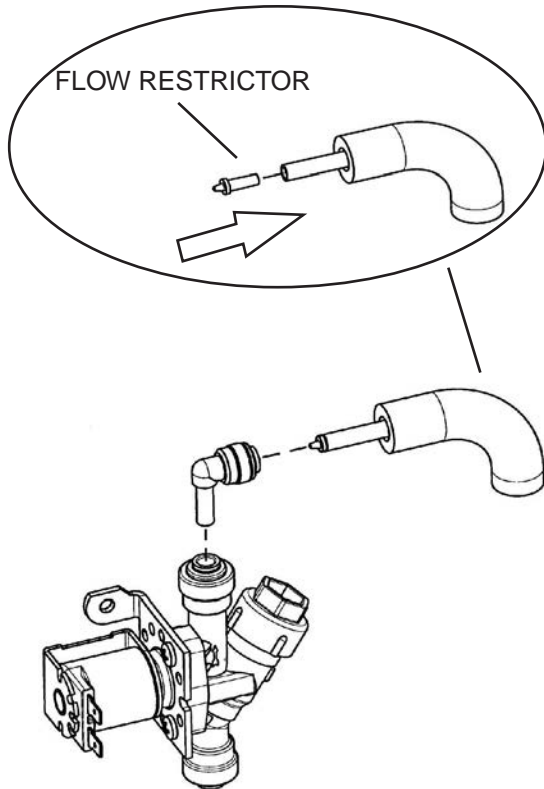

	DESC.	PART #	QTY.
1	PANEL, BOTTLE FILLER UPPER	027624-401	1
2	PANEL, MWSBF LOWER LOUVER STN	027697-005	1
3	SPRING, MSBF	034649-001	1
4	ALCOVE, MSBF	036190-001	1
5	DRAIN, MSBF	036191-001	1
6	GRILLE, MSBF	036192-001	1
7	BUTTON, MSBF	036194-001	1
8	MOUNT, SWITCH	036195-001	1
9	SHELF, ACTIVATION MSBF	036197-001	1
10	SCREW, HEX HD TAPPING	026642-003	14
11	SCREW, FLAT HD TAPPING	026675-003	3
12	SOLENOID VALVE 120V/50-60HZ	201828-01	1
13	LABEL, WIRING DIAGRAM MSBF	030939-002	1
14	FTG, JG ELBOW PLUG IN WHI	029994-103	1
15	BUSHING, STRAIN RELIEF SR6P34	019008	1
16	FTG, JG. ELBOW, PLUG IN	029139-001	1
17	SCREW, PAN HD TAPPING TYPE AB	026630-039	1
18	COVER, ACTIVATION SHELF	036207-001	1
19	TUBE, FILL	036208-001	1
20	FTG, JG. BULKHEAD UNION 3/8	028913-001	1
21	TIE, CABLE 6"	024070-006	1
22	LABEL GROUP, CARTON & UNIT	029583-005	1
23	ANGLE, CRADLE MTG	026210	2
24	BAG, PLASTIC	027270-003	1
25	SCREW, HEX HD TAPPING	026642-023	2
26	INSERT, N' PLATE OASIS GEL BA	020850-004	1
27	LOCK ASSY WITH CAM	031657-004	2
28	WASHER FOR COMPX LOCK	031657-005	2
29	PACKAGING GROUP BF	036466-001	1
30	ELEC CKT DWG W/ LEAD WIRE P/N	036471-001	1
31	KIT, BF ACCESSORIES	036470-001	1
32	SCREW, RD HD MACHINE	026660-006	1
33	NUT, HEX	026824-006	1
34	LOCKWASHER, EXTERNAL TOOTH	021413	1
35	TIMER, SOLID STATE 60 SEC	030973-003	1
36	SCREW, HEX HD MACHINE	026670-028	1
36	SCREW, HEX HD MACHINE	026670-028	1

-THIS FLOW RESTRICTOR IS INTENDED TO MAKE YOUR WATER FLOW AT THE PROPER RATE.

-PRESS THE FLOW RESTRICTOR FIRMLY INTO THE TUBING PROVIDED.

-INSERT THE TUBING WITH THE FLOW RESTRICTOR INTO ELBOW FITTING AT THE TOP FITTING OF THE SOLENOID VALVE.