



VERSAFILLER PVSBF
 Manual, Non-Refrigerated, Vandal-Resistant
 Hydration Station Combo

This surface mount hydration station combo is manually activated. The bottle filler requires a push of the touch-button, while the drinking fountain is activated via the vandal-resistant touch-button

Key Versafiller moulded components shall contain Freshield, which utilises a silver-based antimicrobial compound that reduces the growth of micro-organisms and mildew to protect the surfaces from discolouration, odours and degradation.

Suitable for public building, gymnasiums, sports complexes, hospitals, schools, and offices.



MODEL CODE	PVSBF 507314
ACTIVATION	Bottle Filler: Manual (Touch-button) Drinking Fountain: Manual (Vandal-Resistant Touch-button)
FILTRATION	Green Filter (optional), Built-in 100 micron strainer
AUTO-OFF WATER FLOW	No
DRAINAGE TYPE	Built in drain, Removable drip tray
EXTERIOR CHASSIS	Antimicrobial ABS Plastic, Brushed Stainless Steel
DIMENSIONS	Heavy Duty Galvanised Steel
ALCOVE HEIGHT	960(H) x 413(W) x 473(D)
NET WEIGHT	330 mm
POWER SUPPLY	16 kg
COOLING PERFORMANCE	-
FULL LOAD AMPS	Non-Refrigerated
RATED WATTS	-
ENERGY SYSTEM	-
COUNTRY OF ORIGIN	-
CERTIFICATIONS	Mexico
WARRANTY	ANSI/NSF 61, CABO/ANSI A117.1, ADA, CE (LVD, EMC, RoHS), WRAS
	1 Year

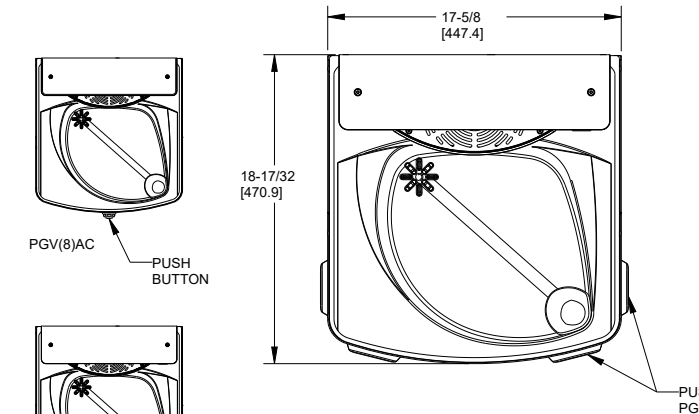

NOTES:

1. TRAP, STOP VALVE AND ELECTRICAL OUTLET NOT FURNISHED.
2. ALLOW 4 INCHES [102MM] MIN. PER SIDE FOR VENTILATION.
- * 3. RECOMMENDED ADULT BARRIER FREE HEIGHT UNINSTALLATION SHOWN. REDUCE HEIGHT BY 3 INCHES FOR INSTALLATIONS USED PRIMARILY BY CHILDREN AGES 12 AND YOUNGER. UNIT SHALL ALSO HAVE A MINIMUM CLEAR FLOOR SPACE 20[760] BY 48[1220]. ADJUST VERTICAL DIMENSIONS AS REQUIRED TO COMPLY WITH FEDERAL, STATE, AND LOCAL CODES.
4. 115V GROUNDED NORTH AMERICAN DUPLEX RECEPTACLE REQUIRED. THIS DRINKING WATER COOLER IS INTENDED TO BE CONNECTED TO A 20A MINIMUM GROUND FAULT CIRCUIT INTERRUPTING (GFCI) DEVICE TO MEET UL REQUIREMENTS.
5. ALL DIMENSIONS ARE IN INCHES. DIMENSIONS IN BRACKETS [] ARE IN MILLIMETERS.

ROUGH-IN DRAWING IS SHOWN WITH A PG8ACSL UNIT IN ORDER TO SHOW THE PROPER HEIGHT OF THE UNIT WHEN RETROFITTED TO THE PARENT UNIT AND HEIGHT FROM THE FLOOR IN ORDER TO COMPLY WITH ADA STANDARDS. THE PG8ACSL UNIT IS NOT INCLUDED WITH THE PURCHASE OF THE PW(F)SBE.

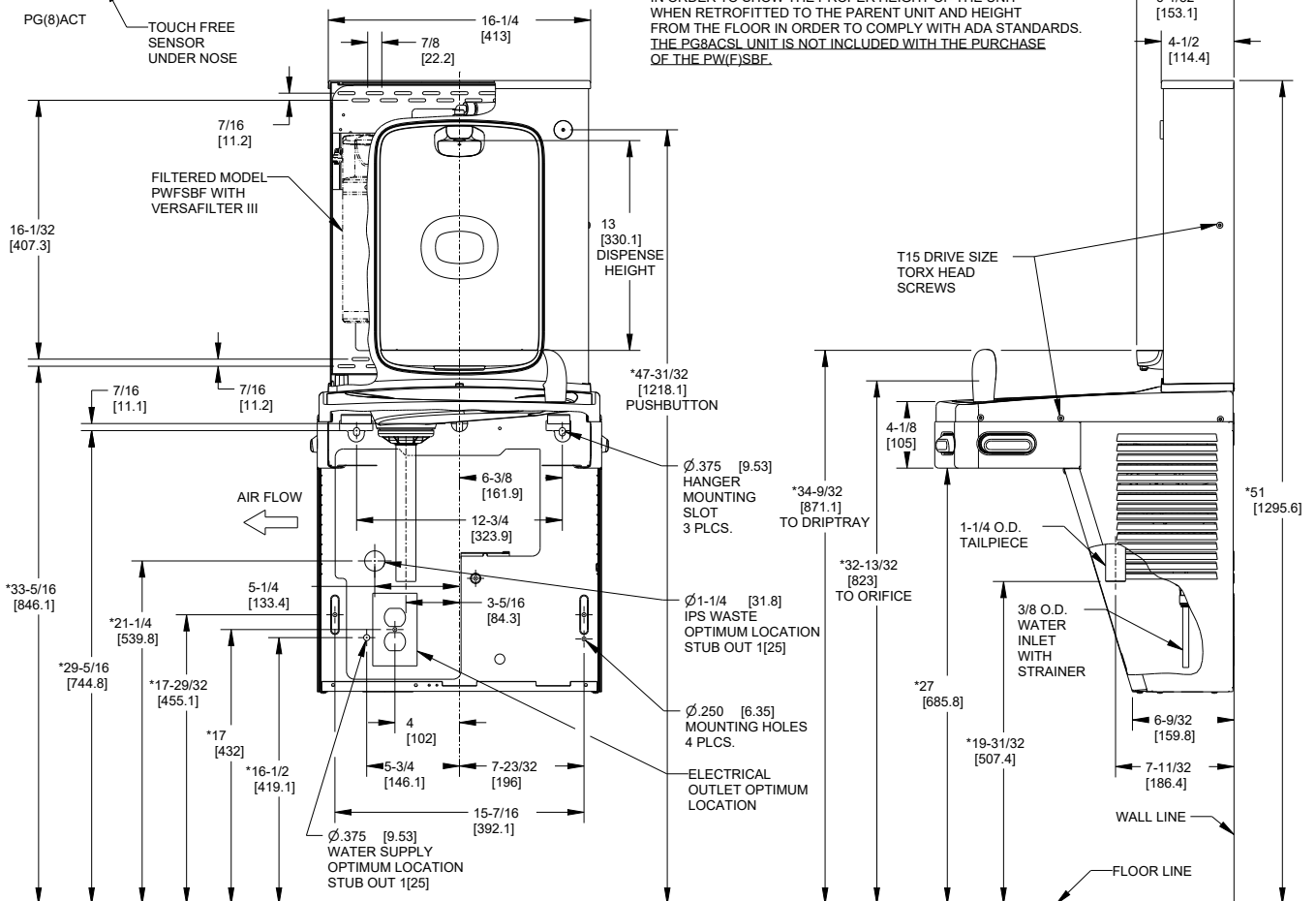

www.oasis.ie
www.oasiscoolers.com
info@oasis.ie

OASIS IRELAND
Bunree Industrial Estate, Ballina,
Co. Mayo, F26 D5R3, Ireland.
+353 96 71222

OASIS POLAND
ul.Gutenberga 20,
44-164, Gliwice, Poland
+48 32 332 65 01