



QUASAR MWEBQY ■ Contactless, Non-Refrigerated
QUASAR MW8EBQY ■ Contactless, Refrigerated
 Bottle Filler

Quasar MWEBQY eliminates your worry; by killing bacteria directly at the spout, to ensure you can enjoy safe drinking water!

Quasar MWEBQY delivers ambient drinking water. This fully recessed mount, bottle filler includes an electronic sensor for a contactless (touch free) activation and a 30 second shut off timer. The Bottle Counter conveniently displays the number of times the unit has been used, encouraging the refill of sports bottles.

Quasar bottle fillers shall have UVC-LED treatment at the point of dispense, which disinfects the water while it is being dispensed; Killing 99.99% of bacteria. UVC-LED also cycles on periodically to keep the dispense-point sanitized between dispenses.

Key Quasar bottle filler moulded components shall contain Freshield, which utilises a silver-based antimicrobial compound that reduces the growth of micro-organisms and mildew to protect the surfaces from discolouration, odours and degradation.

Complies with ANSI A117.1 and ADA. Shall comply with all relevant CE directives (LVD , EMC, RoHS). Shall comply with ANSI/NSF 61.

Suitable for public building, gymnasiums, sports complexes, hospitals, schools, and offices.



MODEL CODE	MW8EBQY 506986E	MWEBQY 506983
ACTIVATION	Contactless (Infrared sensor)	
SENSOR COVERAGE	Up to 5cm (approx.)	
FILTRATION	Green Filter (optional), Built-in 100 micron strainer	
DISINFECTION	Quasar UVC-LED	
AUTO-OFF WATER FLOW	Yes	
DRAINAGE TYPE	Built in drain, Removable drip tray	
EXTERIOR CHASSIS	Antimicrobial ABS Plastic, Brushed Stainless Steel	
DIMENSIONS	Heavy Duty Galvanised Steel	
ALCOVE HEIGHT	1035(H) x 502(W) x 46(D) (287recessed) mm	
NET WEIGHT	35 kg	12 kg
POWER SUPPLY	220-240V, 50/60 Hz	
COOLING PERFORMANCE	60 LPH Rated Capacity & Base Rate (10°C in 21°C amb. temp.)	Non-Refrigerated
FULL LOAD AMPS	2.2A	0.1A
RATED WATTS	347 W	7 W
COUNTRY OF ORIGIN	Mexico	
CERTIFICATIONS	ANSI/NSF 61, CABO/ANSI A117.1, ADA, CE (LVD, EMC, RoHS)	
WARRANTY	1 Year	

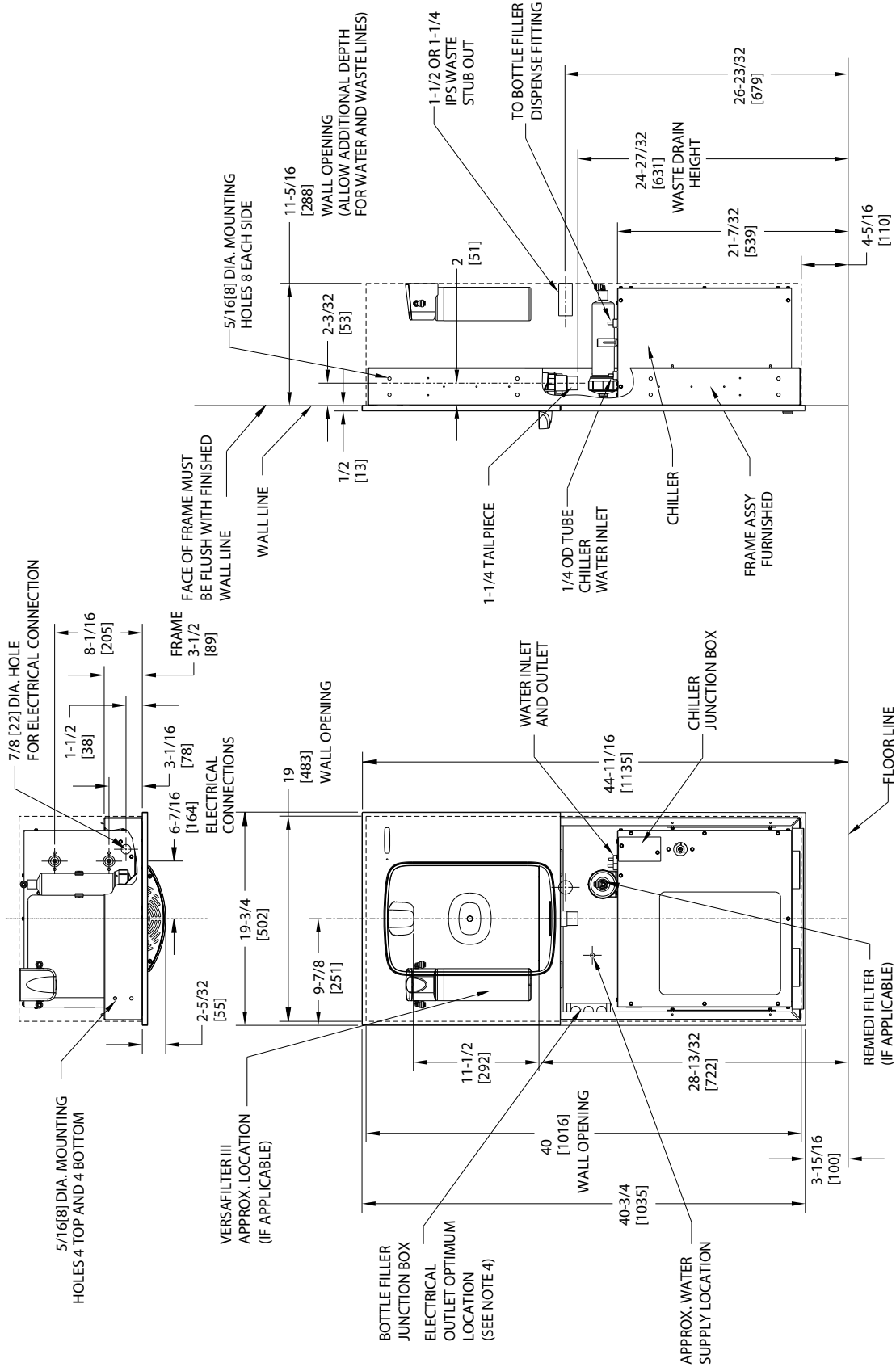

NOTES:

1. RECOMMENDED ADULT HEIGHT INSTALLATION SHOWN. ADJUST VERTICAL DIMENSIONS AS REQUIRED TO COMPLY WITH FEDERAL, STATE AND LOCAL CODES.
2. STOP VALVE, TRAP, PIPE CONNECTOR TO WASTE LINE NOT PROVIDED. SHORT RADIUS TRAP REQUIRED.
3. ALL DIMENSIONS ARE IN INCHES. DIMENSIONS IN [] ARE IN MILLIMETERS.
4. 115V GROUNDING NORTH AMERICAN DUPLEX RECEPTACLE REQUIRED. THIS DRINKING WATER COOLER IS INTENDED TO BE CONNECTED TO A 20A MINIMUM GROUND FAULT CIRCUIT INTERRUPTING (GFCI) DEVICE TO MEET UL REQUIREMENTS.
5. FILTER INSTALLATION LOCATIONS WILL VARY BY MODEL.



www.oasis.ie
www.oasiscoolers.com
info@oasis.ie

OASIS IRELAND
Bunree Industrial Estate, Ballina,
Co. Mayo, F26 D5R3, Ireland.
+353 96 71222

OASIS POLAND
ul. Gutenberga 20,
44-164, Gliwice, Poland
+48 32 332 65 01



CONTACTLESS WATER
OASIS