



M140RSBF ■ Manual, Non-Refrigerated
Hydration Station Combo

This surface mount hydration station combos is manually activated. The bottle filler requires a push of the touch-button, while the drinking fountain is activated via the push-button.

Key moulded components shall contain Freshield, which utilises a silver-based antimicrobial compound that reduces the growth of micro-organisms and mildew to protect the surfaces from discolouration, odours and degradation.

Suitable for public building, gymnasiums, sports complexes, hospitals, schools, and offices.



MODEL CODE	M140RSBF 507453
ACTIVATION	Bottle Filler: Manual (Touch-button) Drinking Fountain: Manual (Push-button)
FILTRATION	Green Filter (optional), Built-in 100 micron strainer
AUTO-OFF WATER FLOW	No
DRAINAGE TYPE	Built in drain, Removable drip tray
EXTERIOR CHASSIS	Antimicrobial ABS Plastic, Brushed Stainless Steel
DIMENSIONS	Heavy Duty Galvanised Steel
ALCOVE HEIGHT	591(H) x 502(W) x 483(D) (90 recessed)
NET WEIGHT	330 mm
POWER SUPPLY	21 kg
COOLING PERFORMANCE	-
FULL LOAD AMPS	Non-Refrigerated
RATED WATTS	-
ENERGY SYSTEM	-
COUNTRY OF ORIGIN	-
CERTIFICATIONS	Mexico
WARRANTY	ANSI/NSF 61, CABO/ANSI A117.1, ADA, CE (LVD, EMC, RoHS), WRAS
	1 Year

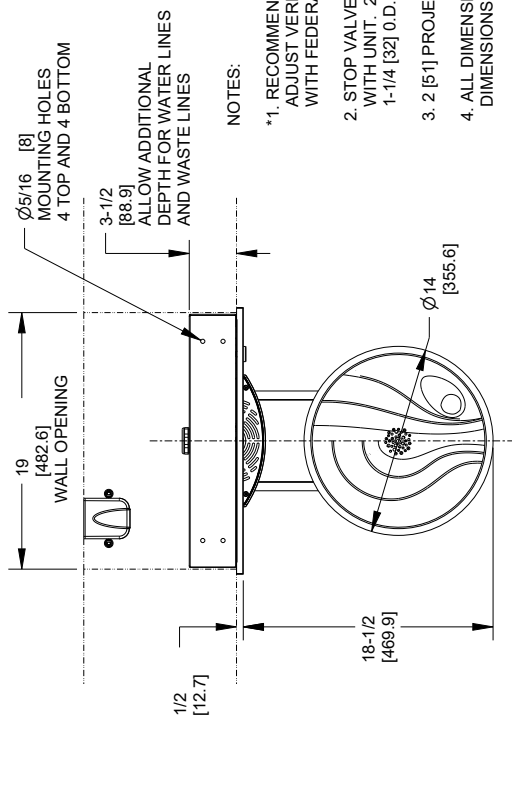

NOTES:

- *1. RECOMMENDED ADULT HEIGHT INSTALLATION SHOWN. ADJUST VERTICAL DIMENSIONS AS REQUIRED TO COMPLY WITH FEDERAL, STATE AND LOCAL CODES.
- 2. STOP VALVE TRAP PIPE CONNECTOR TO WASTE LINE NOT PROVIDED WITH UNIT. 2 [51] PROJECTION OF 1-1/2 [32] PIPE STUB FOR 1-1/4 [32] O.D. WASTE LINE REQUIRED.
- 3. 2 [51] PROJECTION OF 3/8 [9.5] O.D. WATER SUPPLY TUBE REQUIRED.
- 4. ALL DIMENSIONS ARE IN INCHES. DIMENSIONS IN BRACKETS [] ARE IN MILLIMETERS.

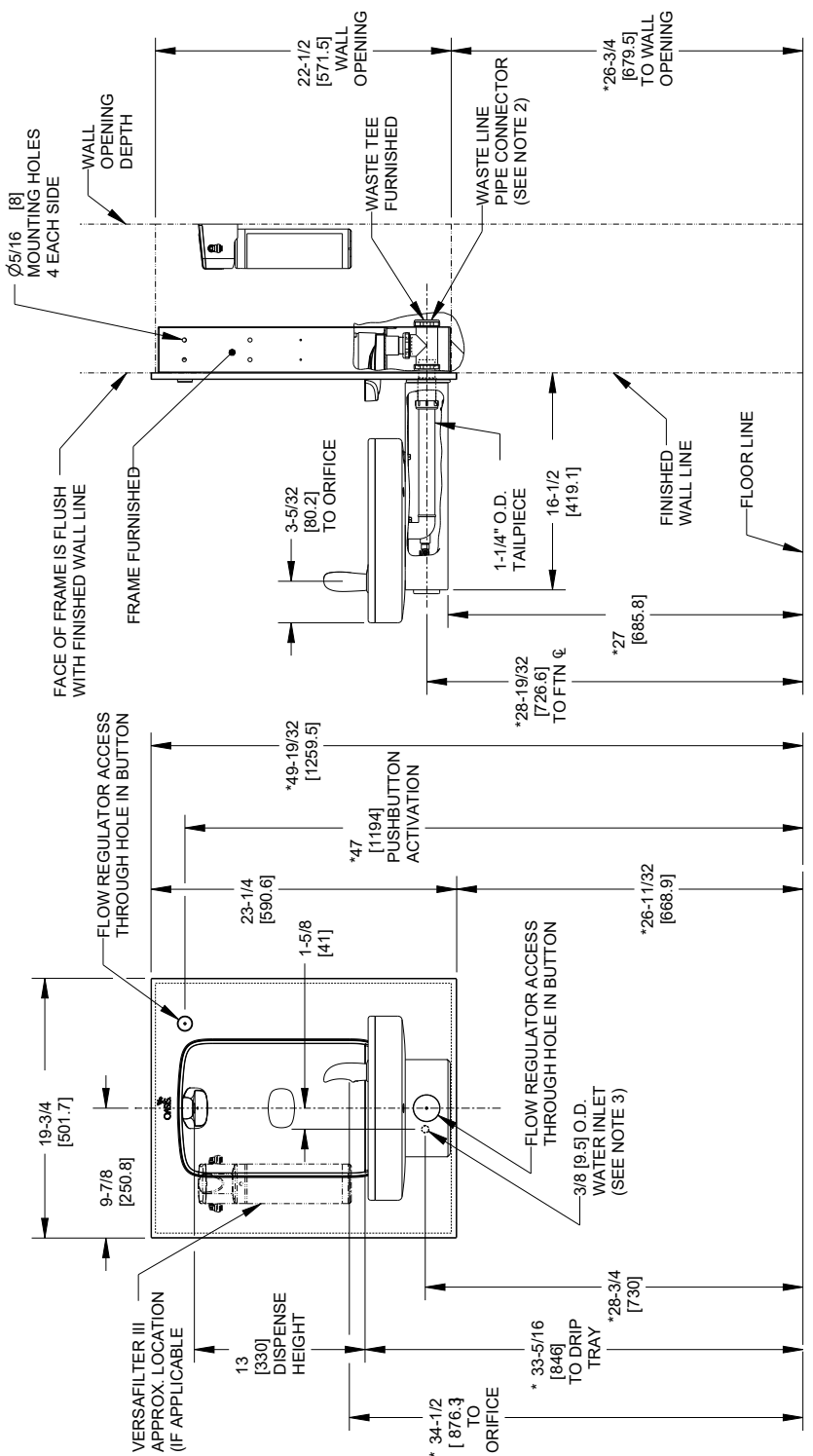

www.oasis.ie
www.oasiscoolers.com
info@oasis.ie

OASIS IRELAND
Bunree Industrial Estate, Ballina,
Co. Mayo, F26 D5R3, Ireland.
+353 96 71222

OASIS POLAND
ul.Gutenberga 20,
44-164, Gliwice, Poland
+48 32 332 65 01