



# Technical Sheet

## QUASAR VersaFiller PWEBQ

Electronic (Touch Free) Retrofit Kit

HYDRATION STATION COMBO



QUASAR

### Standard Features

- Electronic (Touch Free) Surface Mount Retrofit Bottle Filler
- Hands free activation with shut off timer
- Hands free QUASAR with mercury-free UVC-LED treatment at dispense point
- Built in bottle counter, filter monitor and programmable time-out feature
- Large Alcove to fit most sports bottles
- Energy-Efficient LED's illuminate alcove and aid's bottle filling
- Built in drain - no drip tray to empty
- Heavy duty galvanized steel frame
- Standard finish: brushed stainless steel
- ANSI/NSF 61
- CABO/ANSI A117.1

### Options

- Remote Chiller
- green filter
- Installation Kit

**QUASAR VersaFiller PWEBQ** is a Retrofit Bottle Filler. This unit is an Electronic (Touch Free) surface mount bottle filler. It includes an electronic sensor for a no touch activation and a 30 second shut off timer.

Perfect to combine with one of our Versacooler Drinking Fountains.

QUASAR bottle filler shall have UVC-LED treatment at the dispense point, which disinfects the water while it is being dispensed. UVC-LED also cycles on periodically to keep the dispense point sanitized between dispenses.

Key VersaFiller bottle filler molded components shall contain Freshield, which utilizes a silver-based antimicrobial compound that reduces the growth of micro-organisms and mildew to protect the surfaces from discoloration, odours and degradation.

Complies with ANSI A117.1 and ADA. Shall comply with all relevant CE directives (LVD , EMC, RoHS). Shall comply with ANSI/NSF 61.

Suitable for public building, gymnasiums, sports complexes, hospitals, schools, and offices.



By being ADA compliant, OASIS ensures that our products are accessible to people with disabilities.

\*All measurements in mm.

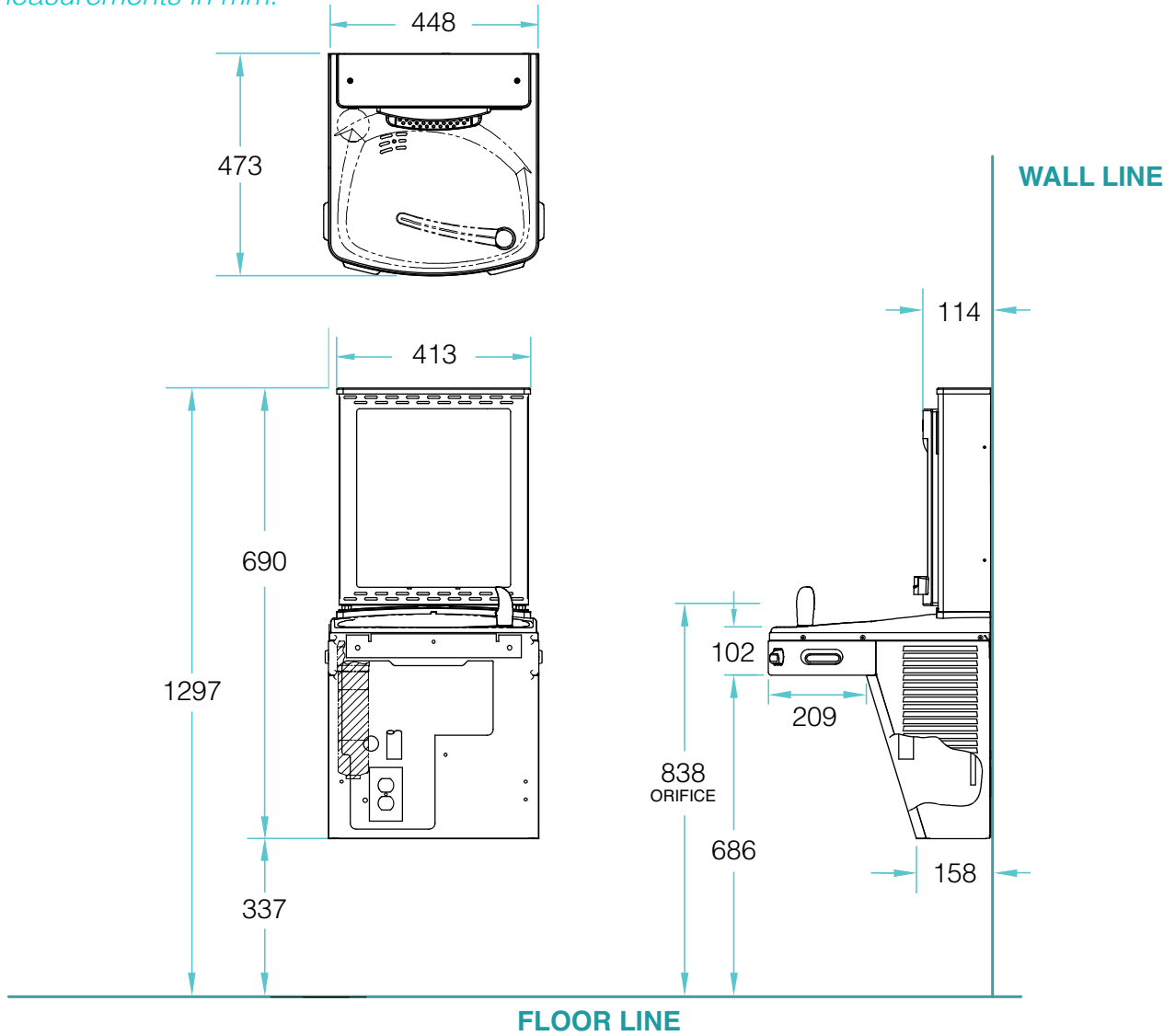

Model	PWEBQ
Type	Electronic (Touch Free) Retrofit Kit
10° C Drinking Water/ 21° C Ambient Air Temp:	
Rated Capacity LPH	
Base Rate LPH	
Pre-Cooler	Non-Refrigerated
Hot'N Cold™ Model	
220-240 Volts, 50/60HZ:	
Compr. HP	
Full Load Amps	0.1
Rated Watts	7
Auto-Off Water Flow	Yes
Glass Filler ACC Option	No
Cabinet Color Option	No
Net Wt. Approx (kg)	5

[www.oasis.ie](http://www.oasis.ie)  
[info@oasis.ie](mailto:info@oasis.ie)

**OASIS IRELAND**

Bunree Industrial Estate, Ballina,  
 Co. Mayo, Ireland, F26 D5R3.  
 +353 96 71222

**OASIS POLAND**

ul. Gutenberga 20,  
 44-164, Gliwice, Poland  
 +48 32 332 65 01