



VERSAFILLER PWSBF RETROFIT KIT.

Manual, Non-Refrigerated

Hydration Station Combo

Versafiller PWSBF retrofits perfectly on top of your existing OASIS Versacooler drinking fountain

This bottle filler is manually activated. The bottle filler requires a push of the touch-button, while the drinking fountain is activated via one of four push-pads.

Key Versafiller moulded components shall contain Freshield, which utilises a silver-based antimicrobial compound that reduces the growth of micro-organisms and mildew to protect the surfaces from discolouration, odours and degradation.

Suitable for public building, gymnasiums, sports complexes, hospitals, schools, and offices.



MODEL CODE	PWSBF
ACTIVATION	Bottle Filler: Manual (Touch-Button) Drinking Fountain: Manual (Four push-pads)
FILTRATION	Green Filter (optional), Built-in 100 micron strainer
AUTO-OFF WATER FLOW	No
DRAINAGE TYPE	Built in drain, Removable drip tray
EXTERIOR CHASSIS	Antimicrobial ABS Plastic, Brushed Stainless Steel
DIMENSIONS	Heavy Duty Galvanised Steel
ALCOVE HEIGHT	480(H) x 413(W) x 144(D)
NET WEIGHT	250 mm
POWER SUPPLY	5 kg
COOLING PERFORMANCE	-
FULL LOAD AMPS	Non-Refrigerated
RATED WATTS	-
ENERGY SYSTEM	-
COUNTRY OF ORIGIN	Mexico
CERTIFICATIONS	ANSI/NSF 61, CABO/ANSI A117.1, ADA, CE (LVD, EMC, RoHS), WRAS
WARRANTY	1 Year

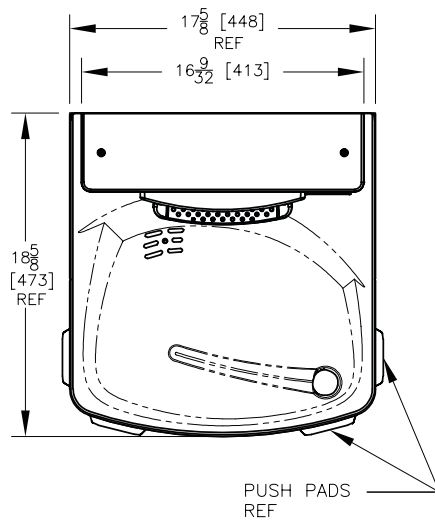

NOTES:

- *1. RECOMMENDED ADULT BARRIER FREE HEIGHT INSTALLATION SHOWN. REDUCE HEIGHT BY 3 INCHES FOR INSTALLATIONS USED PRIMARILY BY CHILDREN AGES 12 AND YOUNGER. UNIT SHALL ALSO HAVE A MINIMUM CLEAR FLOOR SPACE 30[760] BY 48[1220]. ADJUST VERTICAL DIMENSIONS AS REQ'D TO COMPLY WITH FEDERAL, STATE, AND LOCAL CODES.
- 2. 115v GROUNDED NORTH AMERICAN DUPLEX RECEPTACLE REQUIRED. THIS DRINKING WATER COOLER IS INTENDED TO BE CONNECTED TO A 20A MINIMUM GROUND FAULT CIRCUIT INTERRUPTING (GFCI) DEVICE TO MEET UL REQUIREMENTS.
- 3. ALL DIMENSIONS ARE IN INCHES. DIMENSIONS IN BRACKETS [] ARE IN MILLIMETERS.

Rough-in drawing is shown with a PG8AC unit in order to show the proper height of the unit when retrofitted to the parent unit and height from the floor in order to comply with ADA standards. THE PG8AC UNIT IS NOT INCLUDED WITH THE PURCHASE OF THE PWEBF.

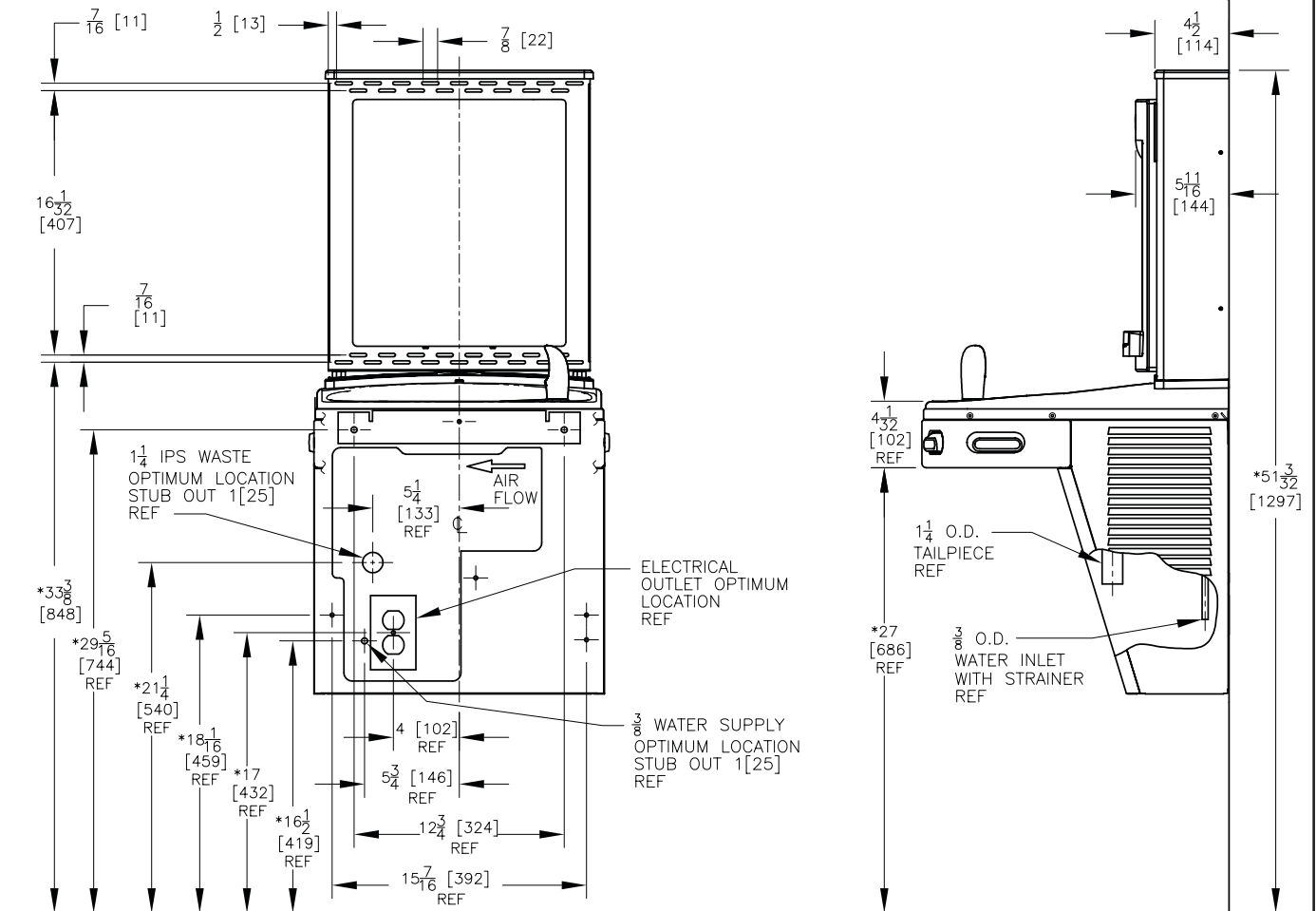

FINISHED FLOOR

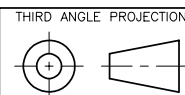

ROUGHING-IN AND DIMENSIONAL DRAWING



www.oasis.ie
www.oasisbottlefillers.com
info@oasis.ie

OASIS IRELAND
Bunree Industrial Estate, Ballina,
Co. Mayo, F26 D5R3, Ireland.
+353 96 71222

OASIS POLAND
ul. Gutenberga 20,
44-164, Gliwice, Poland
+48 32 332 65 01