



F100
Manual, Non-Refrigerated
Drinking Fountain

F100 is a compact surface drinking fountain, ideal for those smaller spaces.

F100 delivers ambient drinking water. This drinking fountain is manually activated via the Dial-A-Drink adjustable bubbler.

Complies with ANSI A117.1 and ADA. Shall comply with all relevant CE directives (LVD , EMC, RoHS). Shall comply with ANSI/NSF 61.

Suitable for public building, gymnasiums, sports complexes, hospitals, schools, and offices.

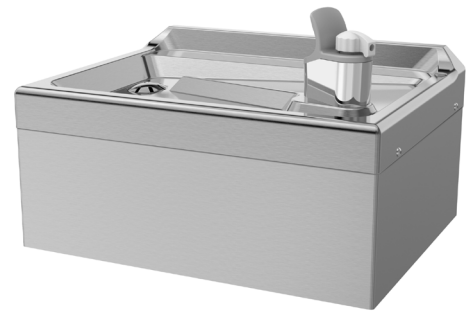

MODEL CODE	F100
ACTIVATION	Mechanical (Dial-A-Drink Adjustable Bubbler with Flexible Bubbler Guard)
FILTRATION	Green Filter (optional), Built-in 100 micron strainer
DISINFECTION	Ultra Blu V (optional)
AUTO-OFF WATER FLOW	No
DRAINAGE TYPE	Built in drain, Removable drip tray
EXTERIOR CHASSIS	Brushed Stainless Steel
DIMENSIONS	Heavy Duty Galvanised Steel
NET WEIGHT	225.4(H) x 432(W) x 331(D) mm
POWER SUPPLY	7 kg
COOLING PERFORMANCE	-
FULL LOAD AMPS	Non-Refrigerated
RATED WATTS	-
ENERGY SYSTEM	-
COUNTRY OF ORIGIN	USA
CERTIFICATIONS	ANSI/NSF 61, CABO/ANSI A117.1, ADA, CE (LVD, EMC, RoHS)
WARRANTY	1 Year

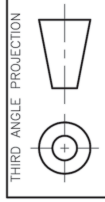
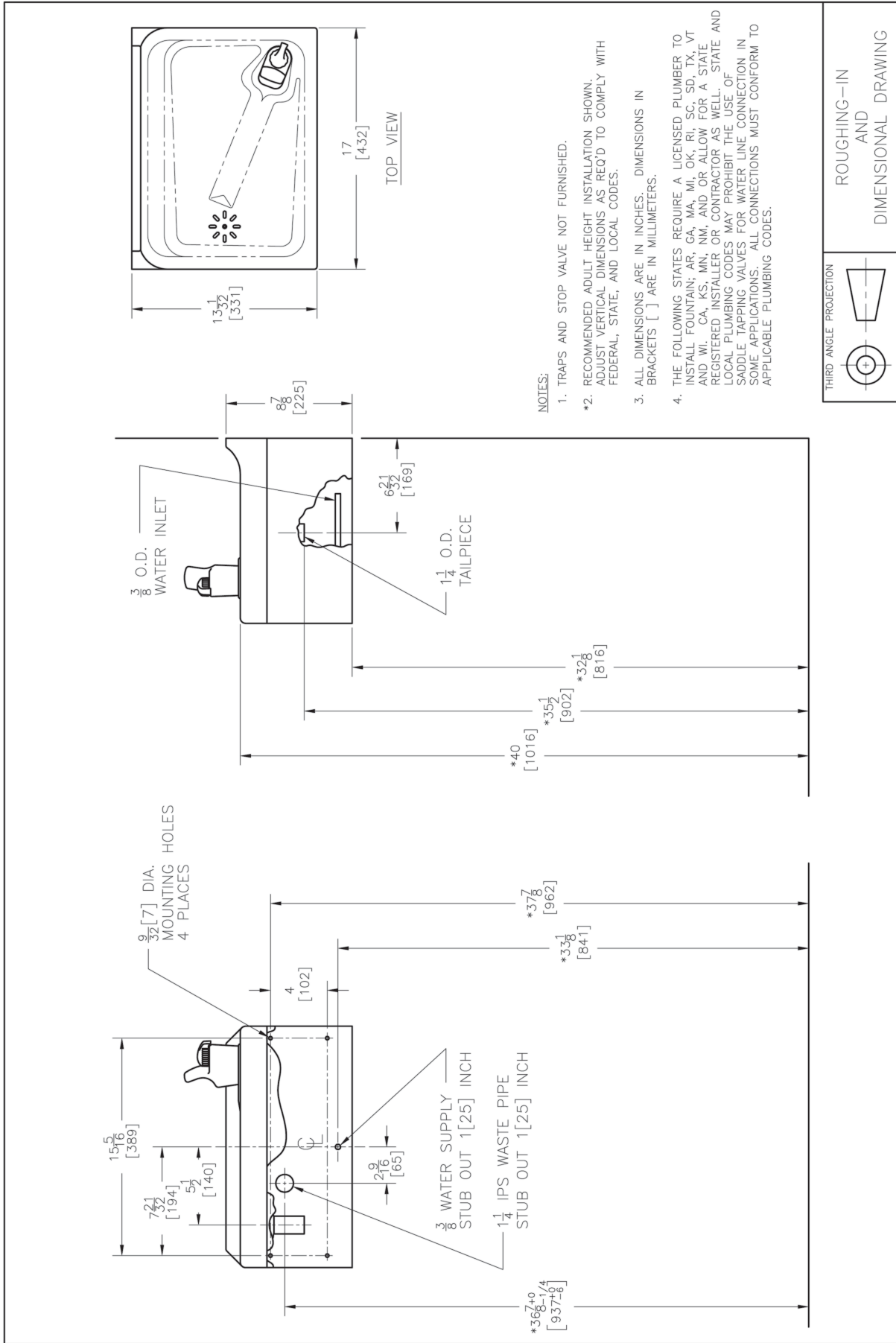

ROUGHING-IN AND DIMENSIONAL DRAWING



www.oasis.ie
www.oasisbottlefillers.com
info@oasis.ie

OASIS IRELAND
Bunree Industrial Estate, Ballina,
Co. Mayo, F26 D5R3, Ireland.
+353 96 71222

OASIS POLAND
ul. Gutenberga 20,
44-164, Gliwice, Poland
+48 32 332 65 01