



AQUAPOINTE PFSZEBFY QUASAR AQUAPOINTE PFSZEBQY

Contactless, Non-Refrigerated
Bottle Filler

The Bottle Filling Station is perfect for those high traffic areas. With a contactless, touch-free activation - there are no fears of cross-contamination.

Designed for urban settings, the sloped top prevents trash being placed on the unit. Additionally, the powder-coat steel finish is highly-durable. This unit can be installed right against the wall to save-space.

The unit is easily serviceable with a top a bottom door for quick access to the filters, electronics and the chiller.

The Bottle Filling Station is comes as standard in white. OASIS is offering custom colours or wrapping - offering commercial value.

Chilled and Non-chilled models are available both with or without Quasar; our UVC LED that kills 99.99% of bacteria at the point of dispense.



NON-CHILLED

MODEL CODE	PFSZEBFY	PFSZEBQY
ACTIVATION	Contactless (Infrared sensor)	
SENSOR COVERAGE	Up to 5cm (approx.)	
FILTRATION	OASIS Green Filter (optional), built-in 100 micron strainer	
DISINFECTION	-	Quasar UVC LED
FLOW RATE	4.2 LPM	
DRAINAGE TYPE	Built-In Drain, Removable drip-tray	
COLOUR	Standard White; Optional custom colours or wrapping.	
EXTERIOR	ABS Plastic, Powder Coated Steel	
CHASSIS	Heavy duty galvanised steel	
DIMENSIONS	150(D) x 600(W) x 1470(H) [mm]	
ALCOVE HEIGHT	265 mm	
NET WEIGHT	25 kg	
INPUT POWER	220-240V, 50/60 Hz	
COOLING PERFORMANCE	-	
TOTAL CURRENT	0.1 A	
POWER CONS.	7 W	
COUNTRY OF ORIGIN	Poland	
CERTIFICATIONS	CE (LVD, EMC, RoHS), WRAS	
WARRANTY	1 Year	

**NON-CHILLED
PFSZEBFY & PFSZEBQY**

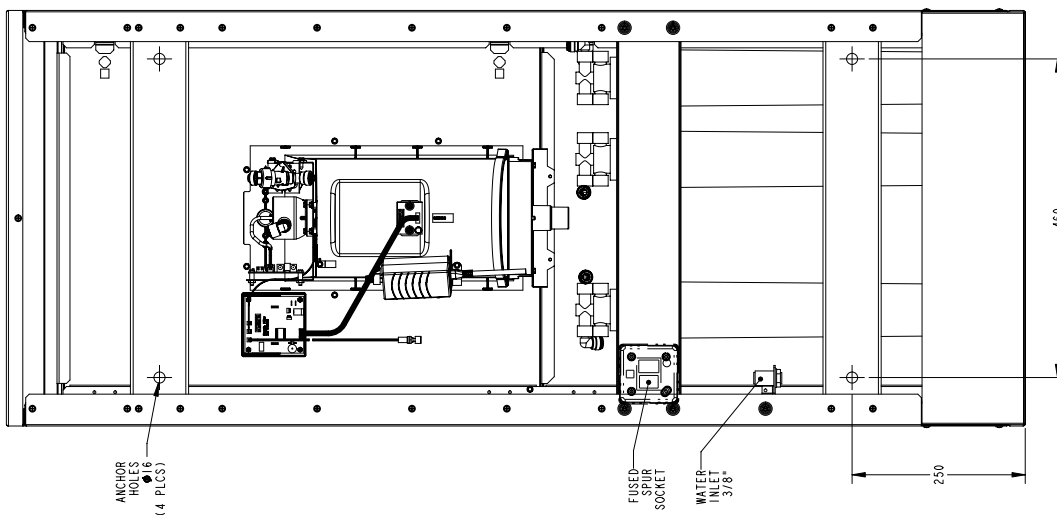
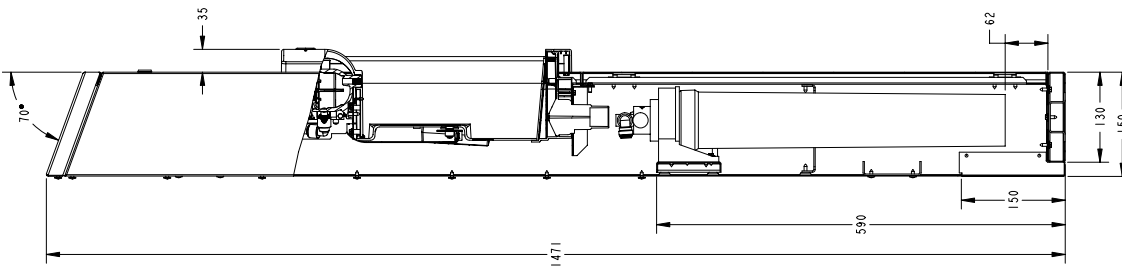
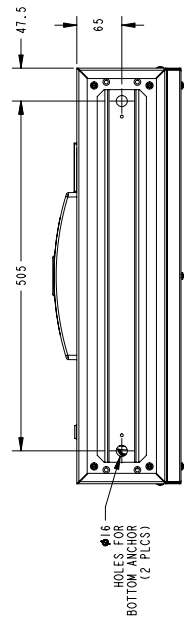
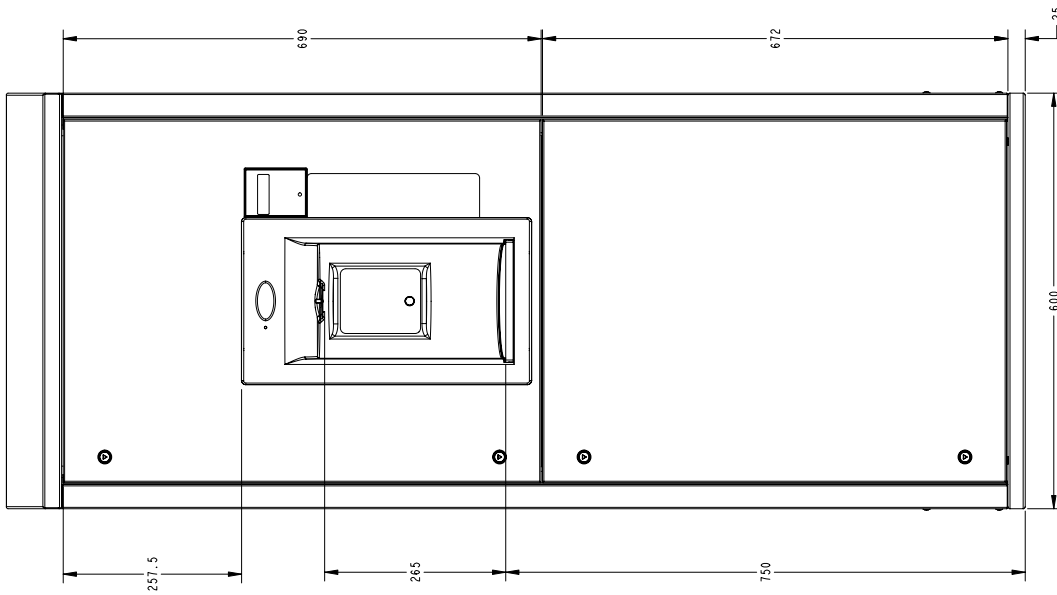

BACKPLATE NOT SHOWN
FOR CLARITY



www.oasis.ie
www.oasisbottlefillers.com
info@oasis.ie

OASIS IRELAND
Bunree Industrial Estate, Ballina,
Co. Mayo, F26 D5R3, Ireland.
+353 96 71222

OASIS POLAND
ul. Gutenberga 20,
44-164, Gliwice, Poland
+48 32 332 65 01



CONTACTLESS
WATER
OASIS