

Following additional parts are required to add glassfiller (029603-004) to standard P8ACY (503961). Please note that it is not possible to remove the bubbler valve from the cooler – the bubbler acts as a vent when pressure builds up in the tank as a result of ice formation.

No	Level	Part Number	Description	Qty	UoM	Note
1	1	035946-001	GLASSFILLER LINE	1	EA	
2	2	200056	BUBBLER FITTING	1	EA	Brass fitting (pipe thread to 1/4 SAE flare) ; Holds g/filler to top
3	2	A021123	RUBBER WASHER	1	EA	For item #2
4	2	A021223	FAUCET ADAPTOR	1	EA	1/4" female SAE flare to 1/4 JG type fitting
5	2	029199-103	FTG, PP UNION TEE	1	EA	Remove plug from cooling tank drain, and fit plug to centre of tee
6	2	029959-002	TUBING, PE 1/4" OD	1.6667	FT	
7	2	028476-001	INSULATION, SPONGE TUBING	1.5833	FT	For item #6
8	2	035353-001	UNION, FILTER PNP	1	EA	Connects item #5 to union fitting on cooling tank drain
9	2	027068	CAP, DUST	1	EA	Covers pipe threads of item #2
10	2	028706-013	WASHER	1	EA	For item #2
11	1	029603-004	GLASSFILLER ASSY	1	EA	

All parts in yellow need to be purchased separately

Installation requires a 7/8" (0.875") diameter hole to be drilled in the top in the position shown below.

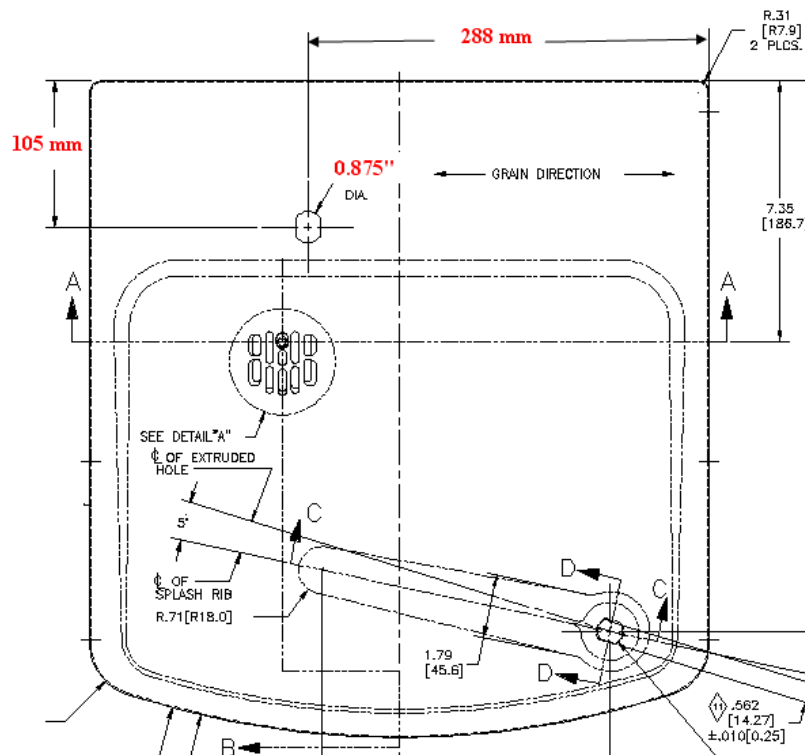

This installation needs to be carried out in the factory – most customers will not be capable of doing this job