

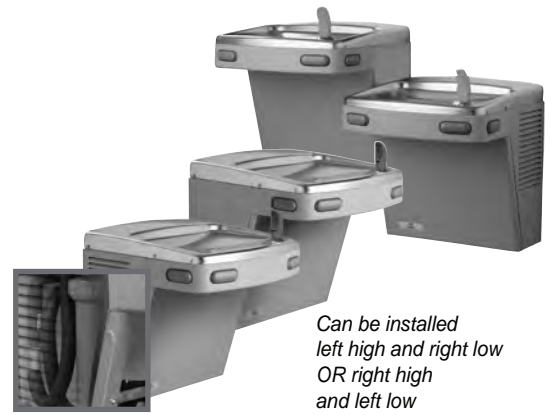

OASIS INTERNATIONAL

Water Coolers



Can be installed
left high and right low
OR right high
and left low

BARRIER-FREE UNIVERSAL VERSACOOLER® II WITH OASIS GREEN FILTRATION SYSTEM

PF8ACSL, PFACSL

Suggested Specification

Model PF8ACSL shall deliver 8.0 gph of 50° F degree water at 90° F ambient and 80° F inlet water. Model PFACSL is a non-refrigerated drinking fountain and delivers ambient water. Shall have Oasis Green Filtration System for taste, odor, lead, and chlorine reduction. Models PF8ACSL and PFACSL shall include front and side push pads to activate the flow of water. Basin shall be designed to eliminate splashing and standing water. Bubbler shall have flexible guard and operate between 20 and 120 PSI. Cabinet finish shall be Sandstone or Greystone powder coated paint on galvanized steel or brushed stainless steel. Cooling system shall use R-134a refrigerant. Shall comply with ANSI A117.1 and ADA. Shall comply with ANSI A117.1 and ADA. Shall be listed by Underwriters' Laboratories to U.S. and Canadian standards. Shall comply with ANSI/NSF 61.

Models

PF8ACSL Delivers 8.0 gallons of chilled drinking water per hour.

PFACSL A non-refrigerated fountain.

These models satisfy CABO/ANSI A117.1. When accessory apron is used on the upper unit, these coolers will comply with ADA guidelines, when properly installed. Apron is not required when installed in an alcove or if a wing wall is stalled on the right side. Models also meet guidelines for children's accessibility providing the floor to orifice height is 30 inches and proper clear floor space is provided for frontal approach.

Standard Features

- > Oasis Green Filtration System for taste, odor, lead and chlorine reduction;
- > Biodegradable Filter
- > Built-in 100 micron strainer stops particles before they enter the waterway
- > Product Certified by NSF to NSF/ANSI Standard 61, including Annex G, (AB953); except for the Green Filter System, which has been tested by independent laboratories to the NSF Standard 42, and 53, but not certified by NSF
- > Waterways are Lead-Free In Materials & Construction
- > Stainless Steel Top
- > Heavy Duty Galvanized steel frame
- > Refrigerant R-134
- > External Stream Height Adjustment
- > Flexible Bubbler Guard
- > High Efficiency Cooling tank and Coil
- > Four Push Pad Activation



Certified to NSF/ANSI 61/Section 9

Finishes

- > Standard Cabinet Finish: Sandstone powder coated paint on galvanized steel
- > Optional finishes (at additional cost): Greystone powder coated paint on galvanized steel
- > Optional finishes (at additional cost): Stainless Steel, Regency Bronze, and optional powder coated finishes

Options (at additional cost)

- > Glass Fillers (Factory Installed)
- > Push Handle (029603-004)
- > Push Back (029603-005)
- > Push Down (029603-006)
- > One Piece Tamperproof, Chrome Plated Brass Bubbler (036700-001)

Installation

- > Prior to roughing consult with local, state, and federal codes for proper mounting height.
- > Shipped with complete instructions and wall mounting bracket.
- > Removable side and front panels provide easy access for installation



ADA Compliant when properly installed.



Components in this fountain are lead free as defined by the Safe Drinking Water Act Amendments of 1986, and the Lead Contamination Control Act of 1988.

Powder Coated Finish Warranty (Continental limits of the United States and Canada): Three years on the powder coat finish provided that the water cooler has not been subjected to abuse, misuse, or alteration.

Limited 5-Year Warranty (Continental limits of the United States and Canada): Five years on the sealed refrigeration system and most component parts. Detailed warranty certificate enclosed with each water cooler; sample available upon request.

Export Warranty: One year on component parts. Detailed warranty certificate enclosed with each drinking fountain; sample copy available upon request.

Models covered by this specification comply with all known Plumbing Codes. Listed by Underwriters' Laboratories to U.S. and Canadian standards.

Model	50° F Drinking Water 90° F Ambient Air Temp*				115 Volts, 60 HZ			Glass Filler Acc. Option	Cabinet Color Finish	Net Wt. Approx.
	Rated Capacity GPH	Base Rate GPH	Pre-Cooler	Hot 'N Cold™ Model	Compr. HP	Full Load Amps	Rated Watts			
PF8ACSL**	8.0	8.0	No	No	1/4	4.4	500	Yes	Yes	84 Lbs.
PFACSL	Fountain Only							Yes	Yes	50 Lbs.

* Industry Standard Rating Condition 80° F inlet water temperature.

**Special export models available, operable on 220-240 volts, 50/60 Hz. UL, CSA and ARI certification not available.

Specifications subject to change without notice

