



## Water Coolers



MODULAR

### M140PM

#### Model

**M140PM** is a non-refrigerated drinking fountain. When the mechanical push-button is depressed, water continues to flow as long as the button is depressed. When this fountain is properly installed it allows your facility to comply with the ADA requirements

#### Standard Features

- > Waterways are Lead-Free in Materials & Construction
- > Stainless Steel Surfaces
- > Heavy-gauge galvanized steel wall mounting frame
- > Limited 1-Year Warranty

#### Finishes

- > Standard Finish: Stainless Steel
- > Optional Finish (at additional cost): Regency Bronze

#### Installation

- > Prior to roughing-in, consult local, state and federal codes for proper mounting height.
- > Wall mounting frame is furnished for easy installation

#### Net Weight

- > Net weight approximately 29 lbs.



Components in this cooler are lead free as defined by the Safe Drinking Water Act Amendments of 1986, and the Lead Contamination Control Act of 1988.

**Limited 1-Year Warranty** (Continental limits of the United States and Canada): One year from date of installation on parts only. Detailed warranty certificate enclosed with each drinking fountain; sample copy available upon request.

**Export Warranty:** One year on component parts. Detailed warranty certificate enclosed with each drinking fountain; sample copy available upon request.

Drinking water coolers shall comply with ANSI A117.1-1992 and ADA frontal approach requirements. Listed by Underwriters' Laboratories to U.S. and Canadian standards.



# OASIS™ BARRIER-FREE MODULAR DRINKING FOUNTAIN MODEL M140PM

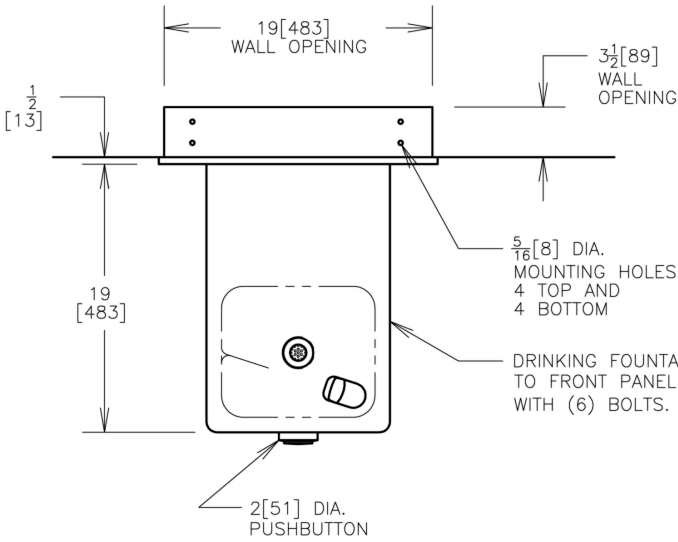

NOTES:

1. STOP VALVE NOT FURNISHED.
- \*2. RECOMMENDED ADULT HEIGHT INSTALLATION SHOWN. ADJUST VERTICAL DIMENSIONS AS REQ'D TO COMPLY WITH FEDERAL, STATE, AND LOCAL CODES.
3. ALL DIMENSIONS ARE IN INCHES. DIMENSIONS IN BRACKETS [ ] ARE IN MILLIMETERS.

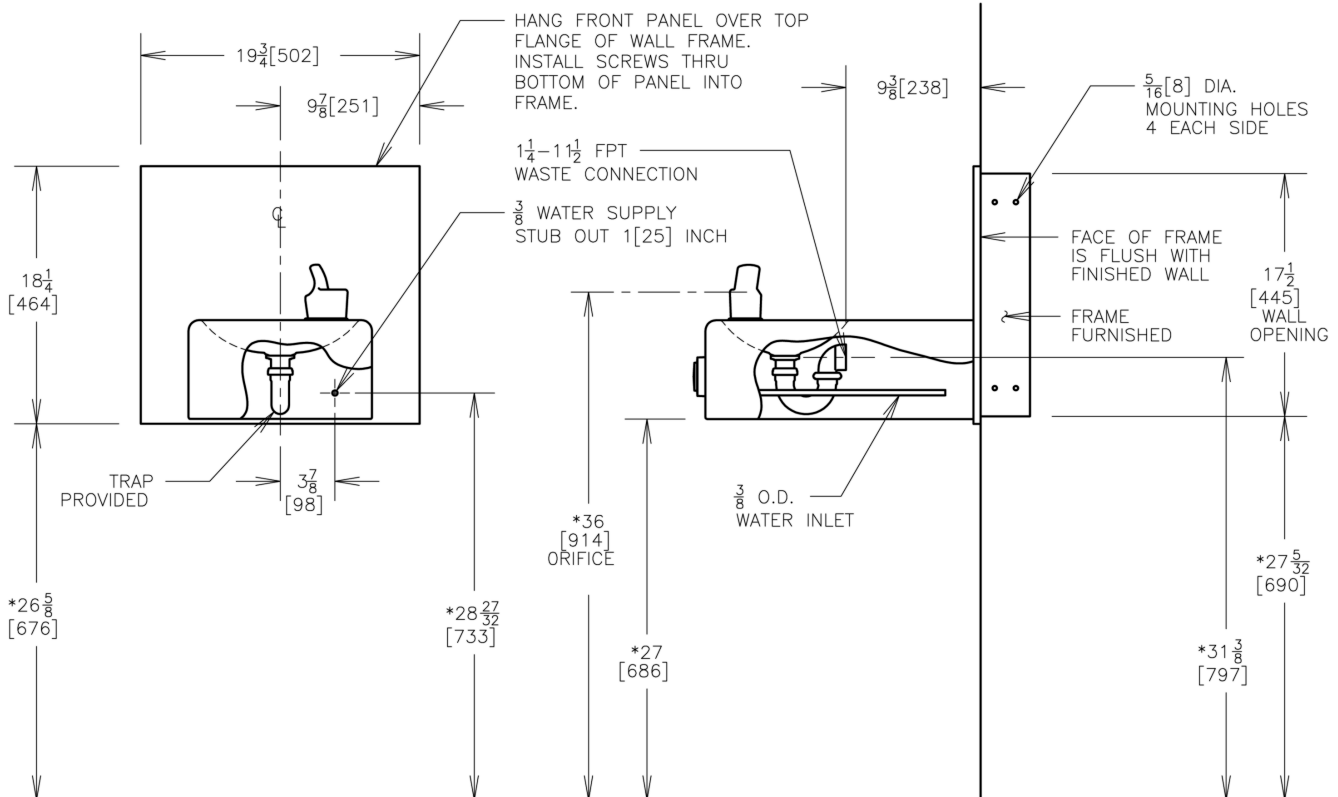

THIRD ANGLE PROJECTION

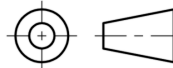

ROUGHING-IN AND DIMENSIONAL DRAWING